



COMPACTRON DISSIMILAR-DOUBLE-TRIODE PENTODE

DESCRIPTION AND RATING

The 6BD11 is a compactron containing a high- μ triode, a medium- μ triode, and a sharp-cutoff pentode. The high- μ triode is intended for general-purpose use, the medium- μ triode for sync separator service, and the pentode for video amplifier service.

GENERAL

ELECTRICAL

Cathode - Coated Unipotential
Heater Characteristics and Ratings
Heater Voltage, AC or DC* 6.3±0.6 Volts
Heater Current† 1.05 Amperes
Direct Interelectrode Capacitances‡

Triode (Section 1)

Grid to Plate: (1Tg to 1Tp) 1.9 pf
Input: 1Tg to (1Tk + 2Tk + Pk + Pg3 + h + i.s.) 3.0 pf
Output: 1Tp to (1Tk + 2Tk + Pk + Pg3 + h + i.s.) 2.2 pf

Triode (Section 2)

Grid to Plate: (2Tg to 2Tp) 3.6 pf
Input: 2Tg to (2Tk + Pk + Pg3 + h + i.s.) 2.4 pf
Output: 2Tp to (2Tk + Pk + Pg3 + h + i.s.) 3.8 pf

Pentode Section

Grid-Number 1 to Plate: (Pg1 to Pp) . 0.13 pf
Input: Pg1 to (2Tk + Pk + Pg2 + Pg3 + h + i.s.) 11 pf
Output: Pp to (2Tk + Pk + Pg2 + Pg3 + h + i.s.) 4.6 pf
Pentode Plate to Triode Plate (Section 2): (Pp to 2Tp), maximum 0.045 pf
Triode Plate (Section 1) to Triode Plate (Section 2): (1Tp to 2Tp), maximum 0.075 pf

MECHANICAL

Operating Position - Any
Envelope - T-9, Glass
Base - E12-70, Button 12-Pin
Outline Drawing - EIA 9-58
Maximum Diameter 1.188 Inches
Maximum Over-all Length 2.375 Inches
Maximum Seated Height 2.000 Inches

PHYSICAL DIMENSIONS

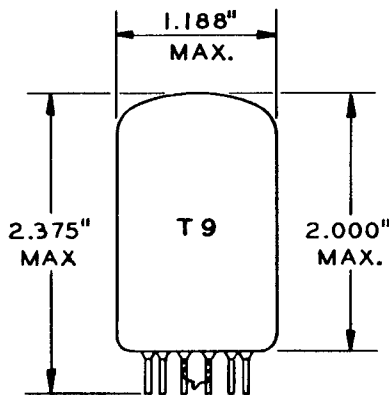

EIA 9-58

TERMINAL CONNECTIONS

- Pin 1 - Heater
- Pin 2 - Pentode Plate
- Pin 3 - Triode Grid (Section 2)
- Pin 4 - Triode Plate (Section 2)
- Pin 5 - Triode Cathode (Section 1)
- Pin 6 - Triode Grid (Section 1)
- Pin 7 - Triode Cathode (Section 2) and Internal Shield
- Pin 8 - Triode Plate (Section 1)
- Pin 9 - Pentode Cathode, Grid Number 3, and Internal Shield
- Pin 10 - Pentode Grid Number 2 (Screen)
- Pin 11 - Pentode Grid Number 1
- Pin 12 - Heater

BASING DIAGRAM

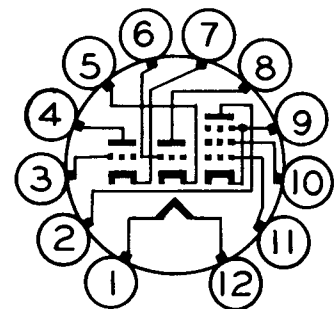

EIA 12DP

The tubes and arrangements disclosed herein may be covered by patents of General Electric Company or others. Neither the disclosure of any information herein nor the sale of tubes by General Electric Company conveys any license under patent claims covering combinations of tubes with other devices or elements. In the absence of an

express written agreement to the contrary, General Electric Company assumes no liability for patent infringement arising out of any use of the tubes with other devices or elements by any purchaser of tubes or others.

MAXIMUM RATINGS

DESIGN-MAXIMUM VALUES

Pentode Section

Plate Voltage	330	Volts
Screen-Supply Voltage	330	Volts
Screen Voltage - See Screen Rating Chart		
Positive DC Grid-Number 1 Voltage	0	Volts
Plate Dissipation	4.0	Watts
Screen Dissipation	1.1	Watts
Heater-Cathode Voltage		
Heater Positive with Respect to Cathode		
DC Component	100	Volts
Total DC and Peak	200	Volts
Heater Negative with Respect to Cathode		
Total DC and Peak	200	Volts
Grid-Number 1 Circuit Resistance		
With Fixed Bias	1.0	Megohms
With Cathode Bias	1.0	Megohms

Triode (Section 1)

Plate Voltage	330	Volts
Positive DC Grid Voltage	0	Volts
Plate Dissipation	1.5	Watts
Heater-Cathode Voltage		
Heater Positive with Respect to Cathode		
DC Component	100	Volts
Total DC and Peak	200	Volts
Heater Negative with Respect to Cathode		
Total DC and Peak	200	Volts
Grid Circuit Resistance		
With Fixed Bias	0.5	Megohms
With Cathode Bias	1.0	Megohms

Triode (Section 2)

Plate Voltage	330	Volts
Positive DC Grid Voltage	0	Volts
Plate Dissipation	2.0	Watts
Heater-Cathode Voltage		
Heater Positive with Respect to Cathode		
DC Component	100	Volts
Total DC and Peak	200	Volts
Heater Negative with Respect to Cathode		
Total DC and Peak	200	Volts
Grid Circuit Resistance		
With Fixed Bias	0.5	Megohms
With Cathode Bias	1.0	Megohms

Design-Maximum ratings are limiting values of operating and environmental conditions applicable to a bogey electron tube of a specified type as defined by its published data and should not be exceeded under the worst probable conditions.

The tube manufacturer chooses these values to provide acceptable serviceability of the tube, making allowance for the effects of changes in operating conditions due to variations in the characteristics of the tube under consideration.

The equipment manufacturer should design so that initially and throughout life no design-maximum value for the intended service is exceeded with a bogey tube under the worst probable operating conditions with respect to supply-voltage variation, equipment component variation, equipment control adjustment, load variation, signal variation, environmental conditions, and variations in the characteristics of all other electron devices in the equipment.

CHARACTERISTICS AND TYPICAL OPERATION

AVERAGE CHARACTERISTICS

Pentode Section

Plate Voltage	35	135	Volts
Screen Voltage	135	135	Volts
Grid-Number 1 Voltage	0§	---	Volts
Cathode-Bias Resistor	---	100	Ohms
Plate Resistance, approximate	---	45000	Ohms
Transconductance	---	10400	Micromhos
Plate Current	34	17	Milliamperes
Screen Current	13	4.0	Milliamperes
Grid-Number 1 Voltage, approximate Ib = 100 Microamperes	---	-6	Volts

Triode (Section 1)

Plate Voltage	200	Volts
Grid Voltage	-2.0	Volts
Amplification Factor	68	
Plate Resistance, approximate	12400	Ohms
Transconductance	5500	Micromhos
Plate Current	7.0	Milliamperes
Grid Voltage, approximate Ib = 100 Microamperes	-5.5	Volts

Triode (Section 2)

Plate Voltage	200	Volts
Cathode-Bias Resistor	220	Ohms
Amplification Factor	41	
Plate Resistance, approximate	9400	Ohms
Transconductance	4400	Micromhos
Plate Current	9.2	Milliamperes
Grid Voltage, approximate Ib = 100 Microamperes	-6.5	Volts

NOTES

- * The equipment designer should design the equipment so that heater voltage is centered at the specified bogey value, with heater supply variations restricted to maintain heater voltage within the specified tolerance.
- † Heater current of a bogey tube at Ef = 6.3 volts.
- ‡ Without external shield.
- § Applied for short interval (two seconds maximum) so as not to damage tube.

SCREEN RATING CHART
 PENTODE SECTION

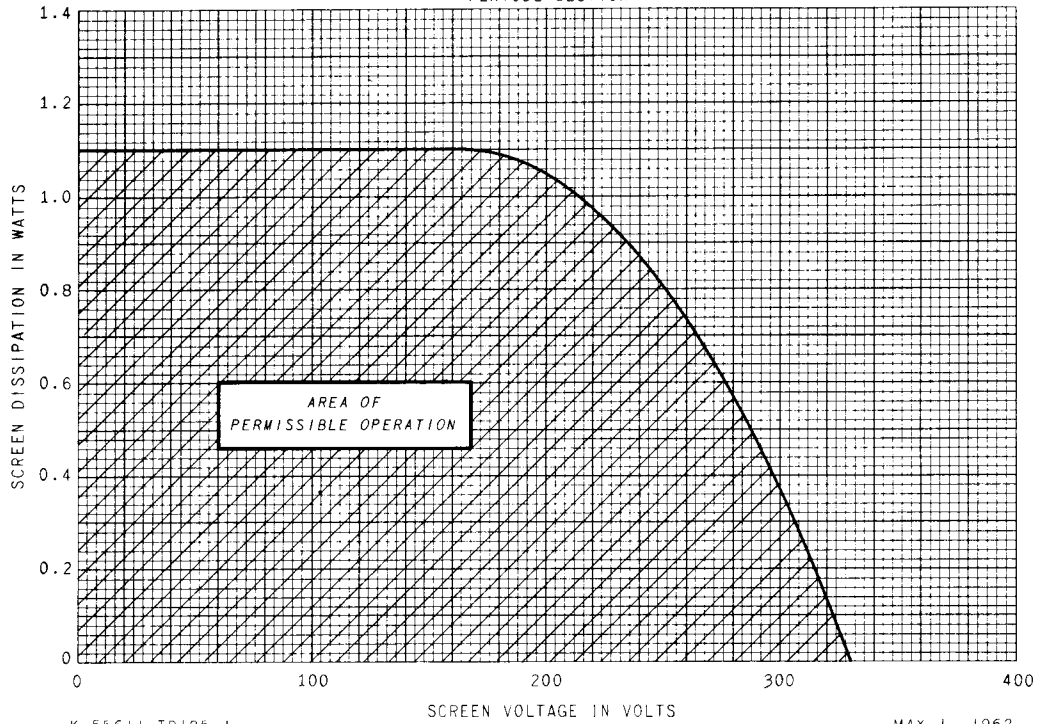

AVERAGE PLATE CHARACTERISTICS
 PENTODE SECTION

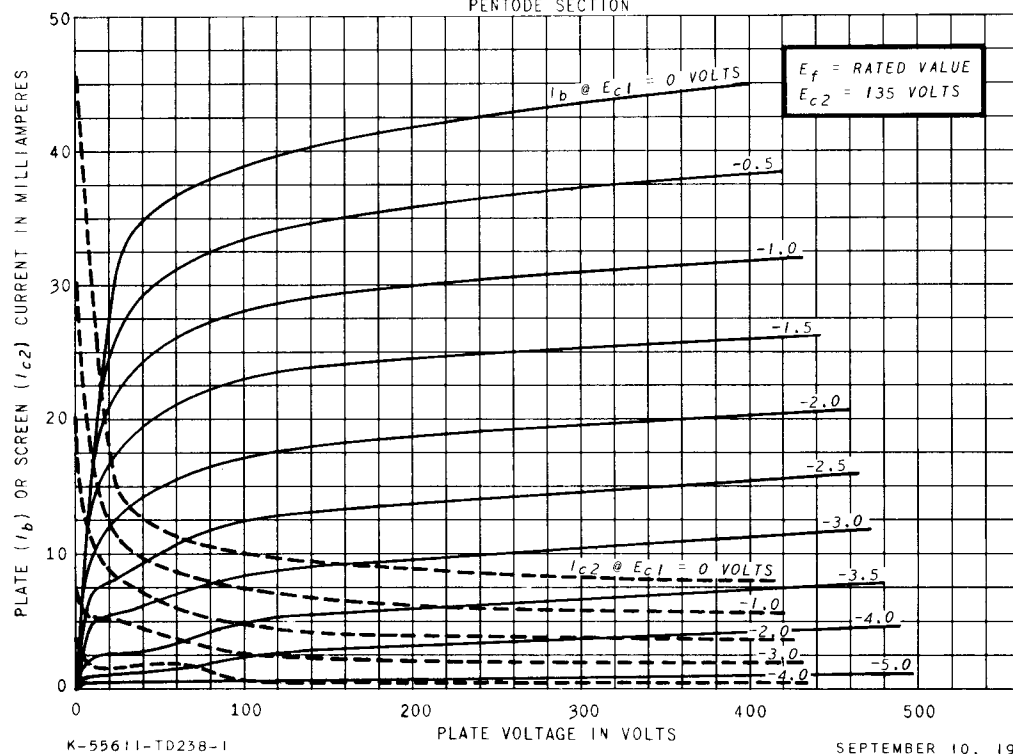

AVERAGE PLATE CHARACTERISTICS

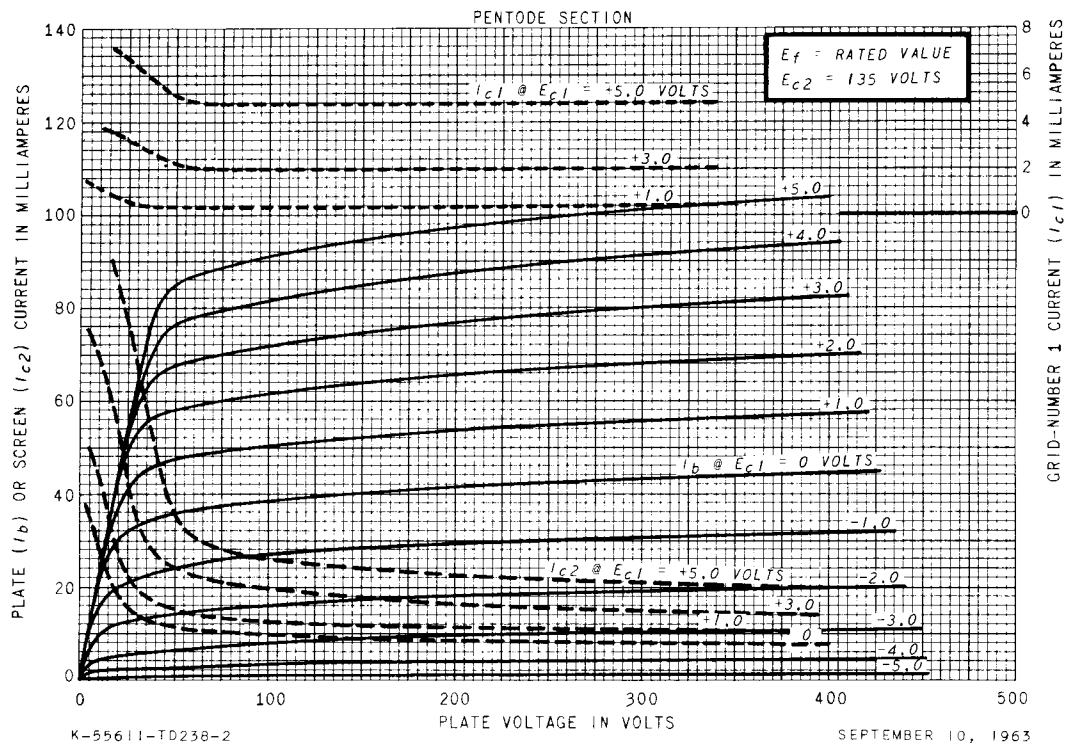

AVERAGE PLATE CHARACTERISTICS

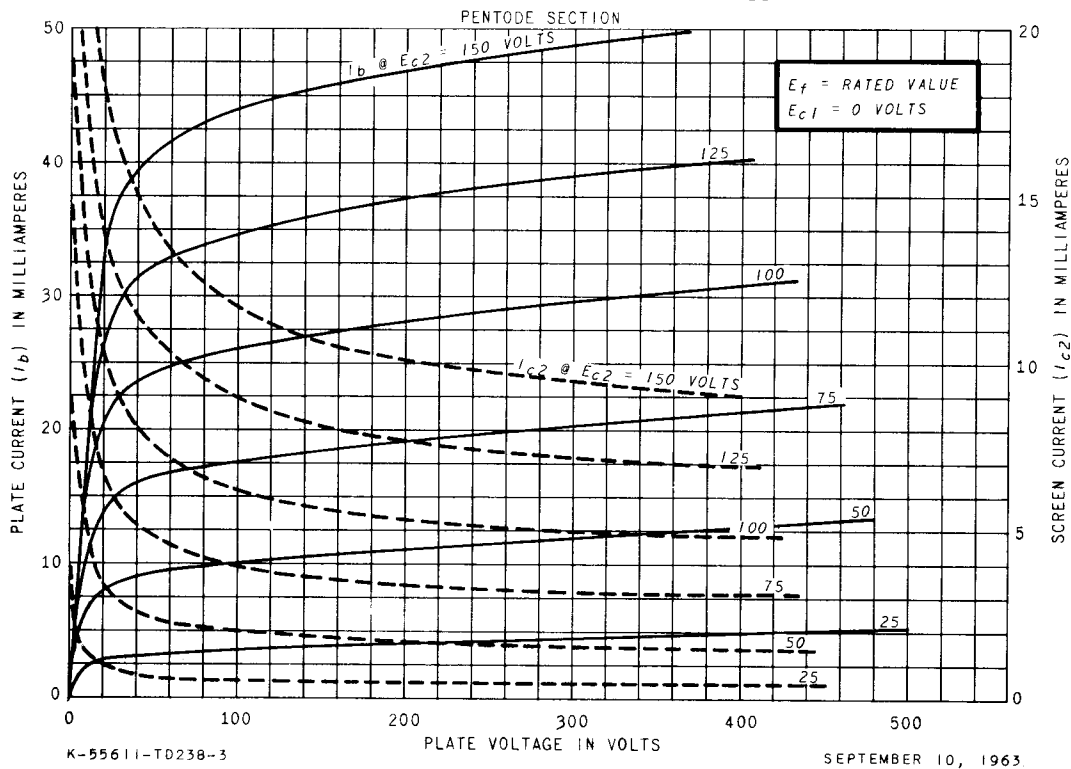

AVERAGE TRANSFER CHARACTERISTICS

PENTODE SECTION

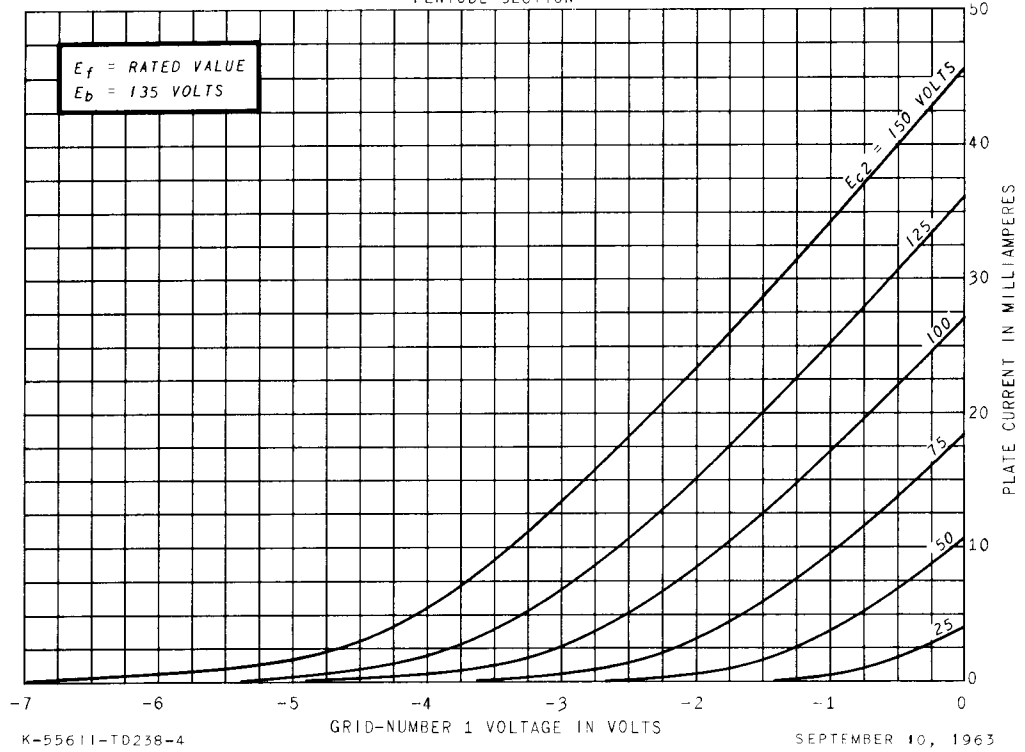

AVERAGE TRANSFER CHARACTERISTICS

PENTODE SECTION

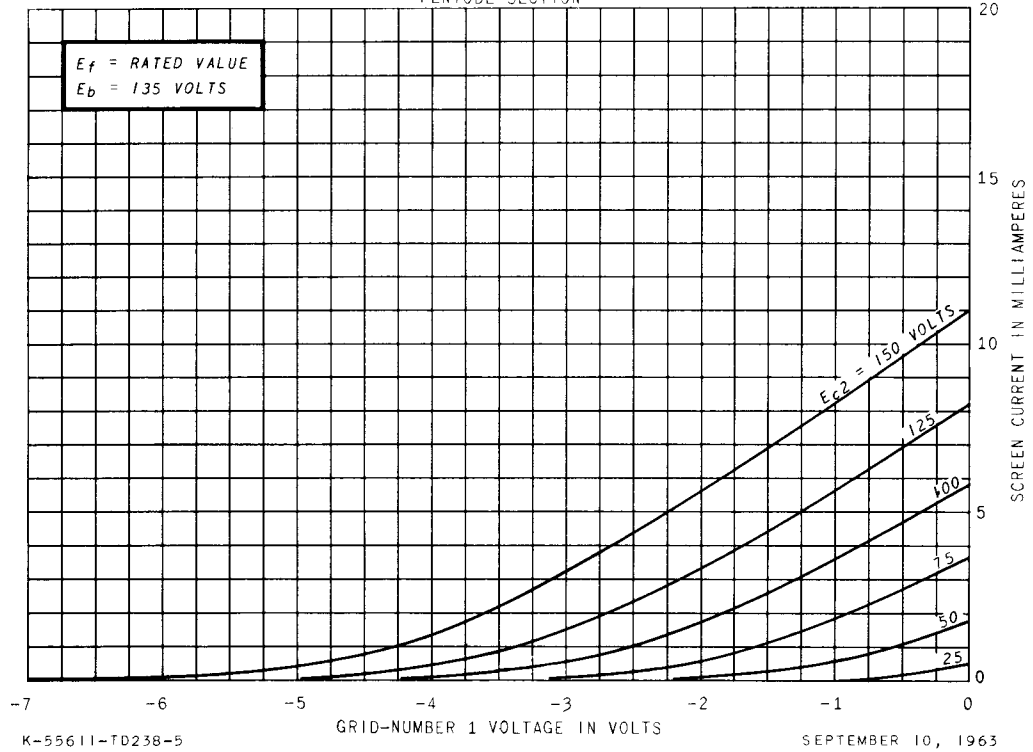

AVERAGE TRANSFER CHARACTERISTICS

PENTODE SECTION

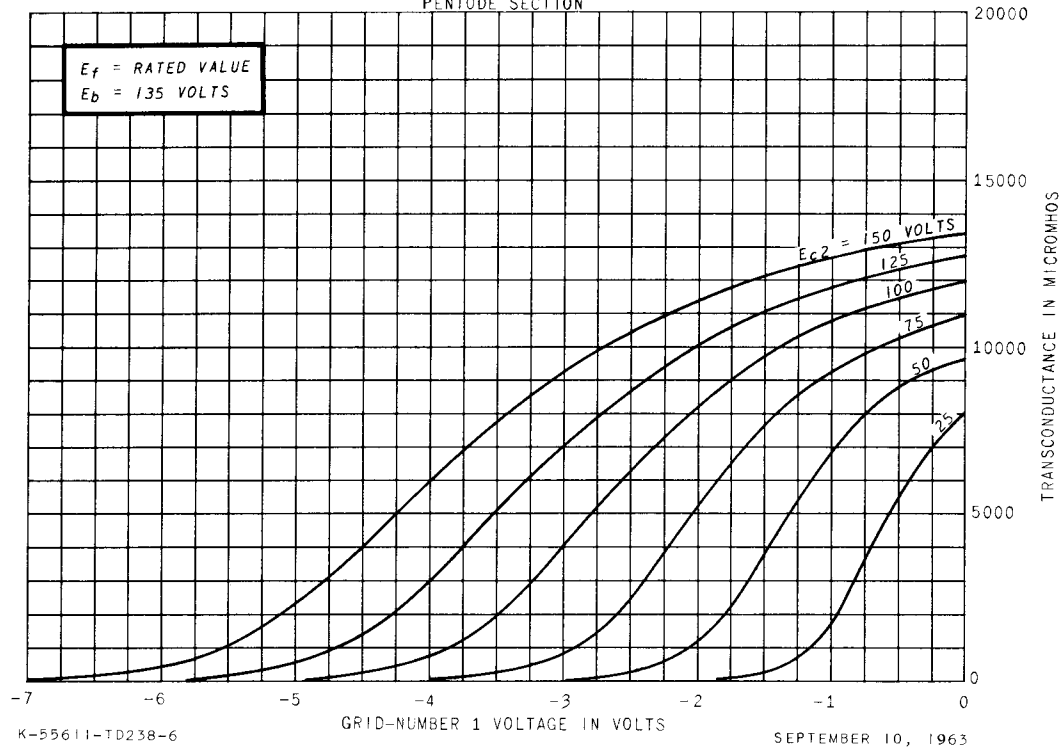

AVERAGE PLATE CHARACTERISTICS

TRIODE SECTION 1

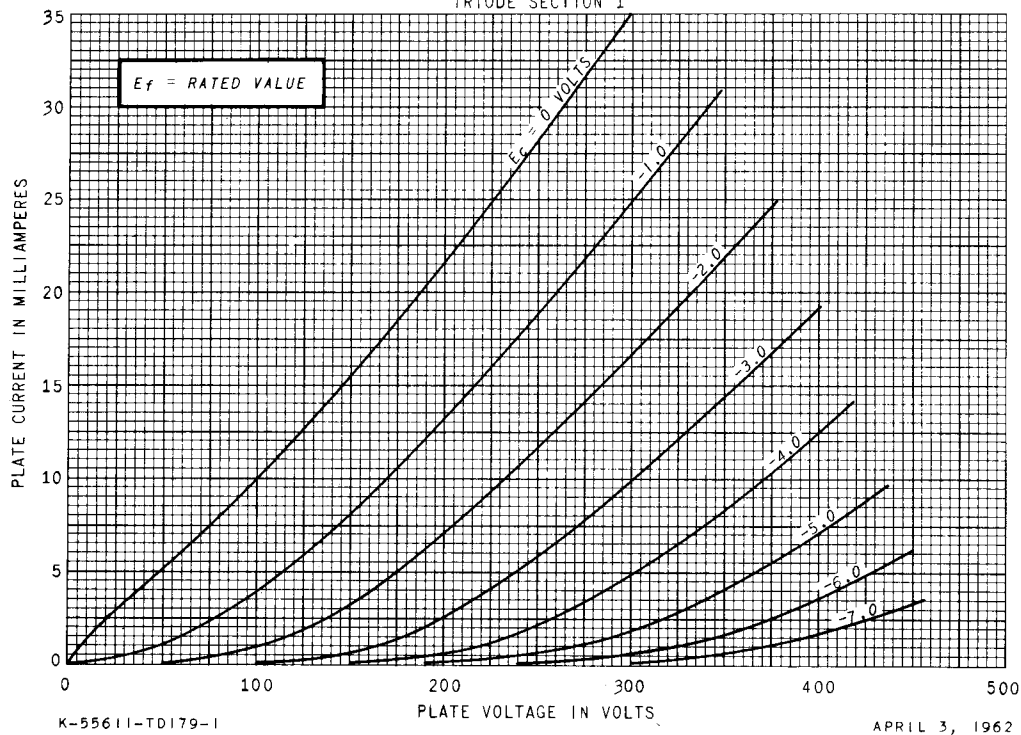

AVERAGE TRANSFER CHARACTERISTICS

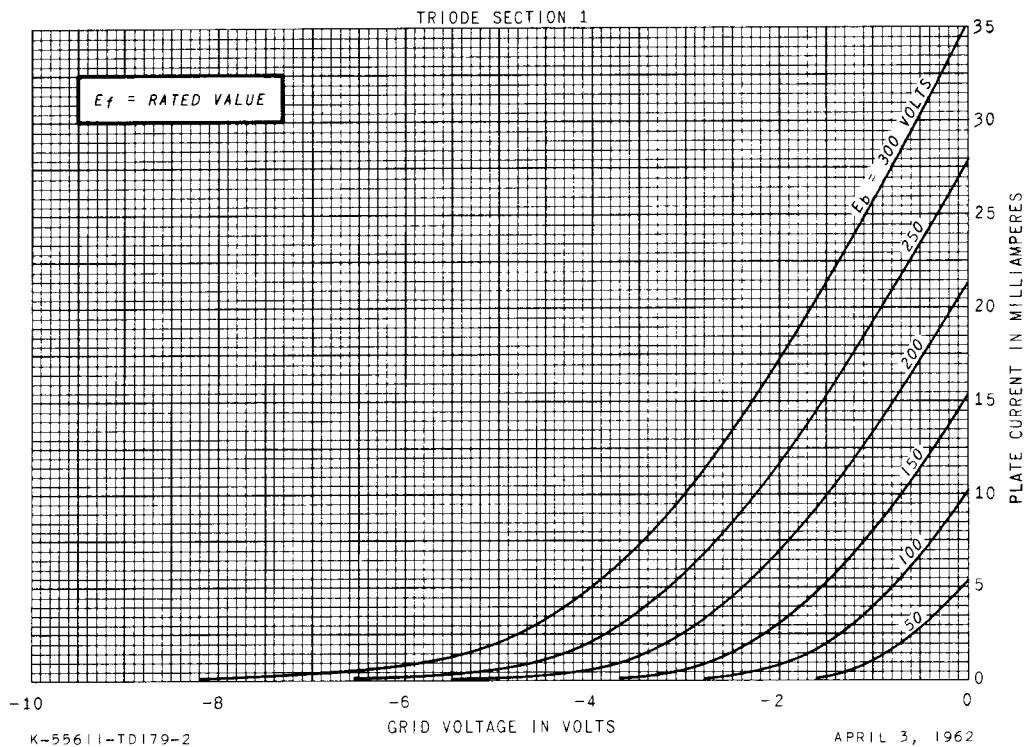

AVERAGE CHARACTERISTICS

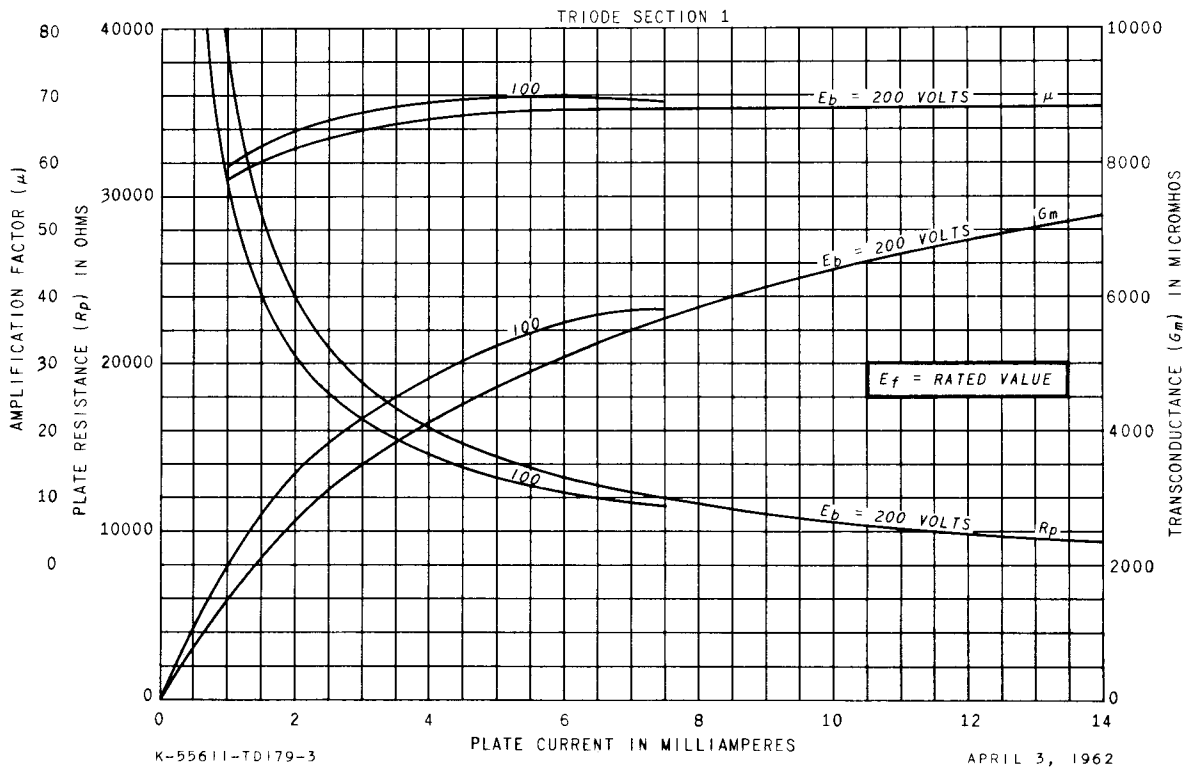

AVERAGE PLATE CHARACTERISTICS

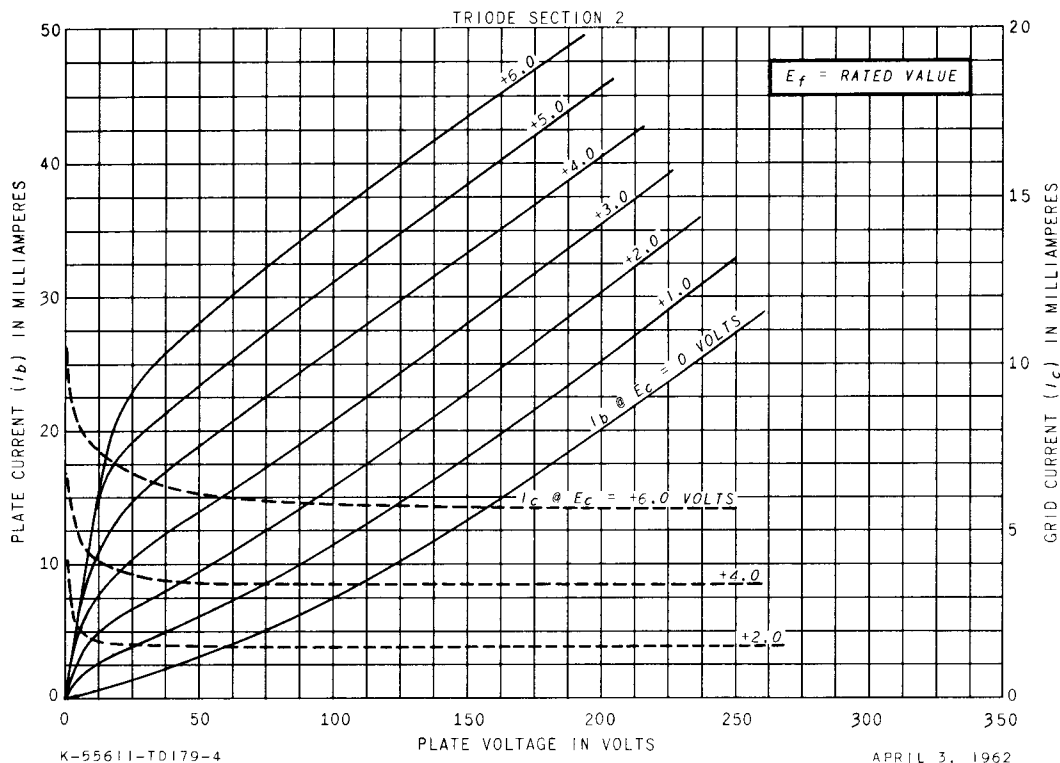

AVERAGE PLATE CHARACTERISTICS

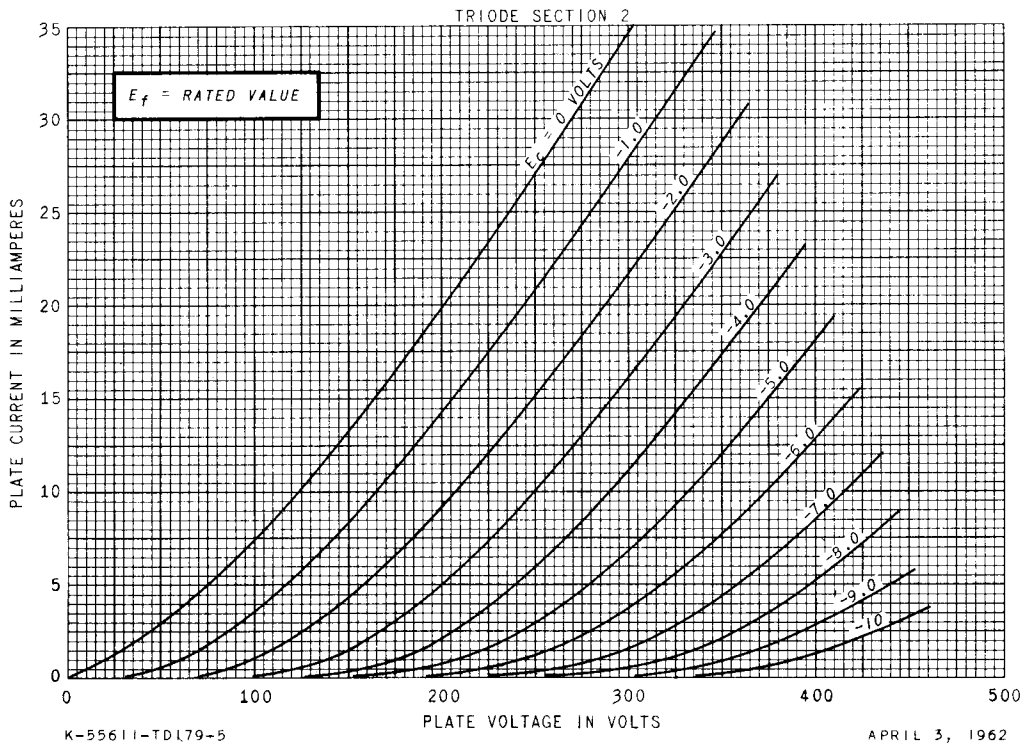

AVERAGE TRANSFER CHARACTERISTICS

TRIODE SECTION 2

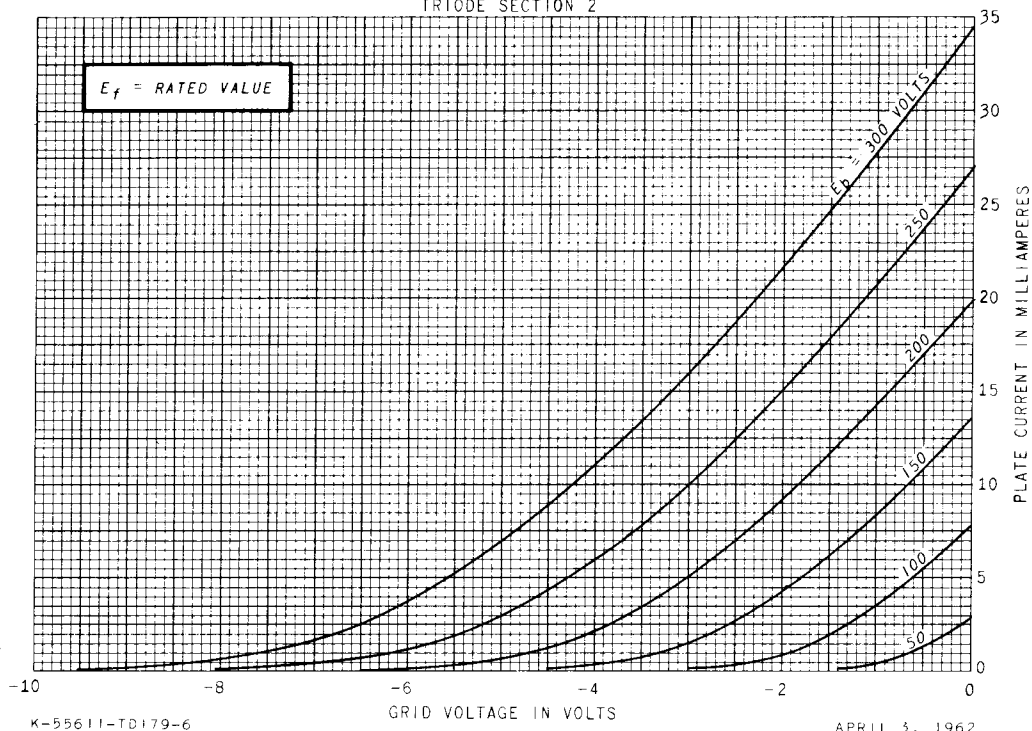

AVERAGE CHARACTERISTICS

TRIODE SECTION 2

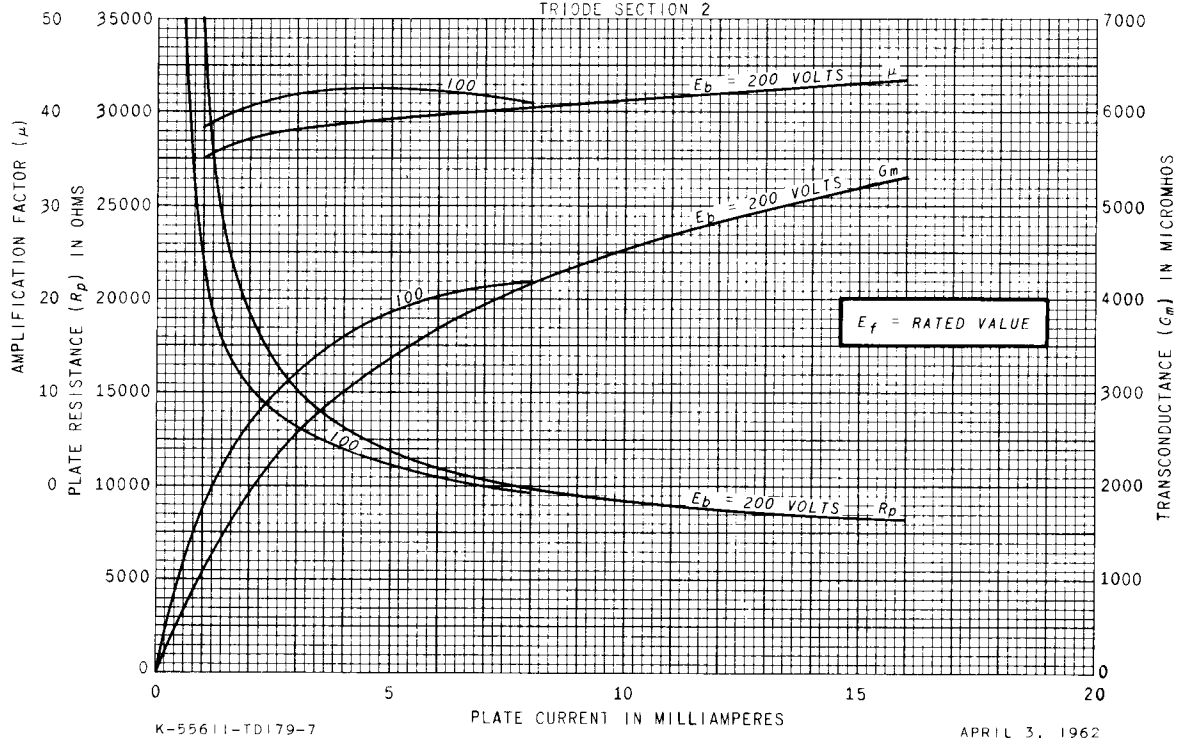

TUBE DEPARTMENT



Owensboro, Kentucky