

CBS-COLORTRON 15HP22

DATA AND APPLICATION NOTES

15HP22

CBS-COLORTRON

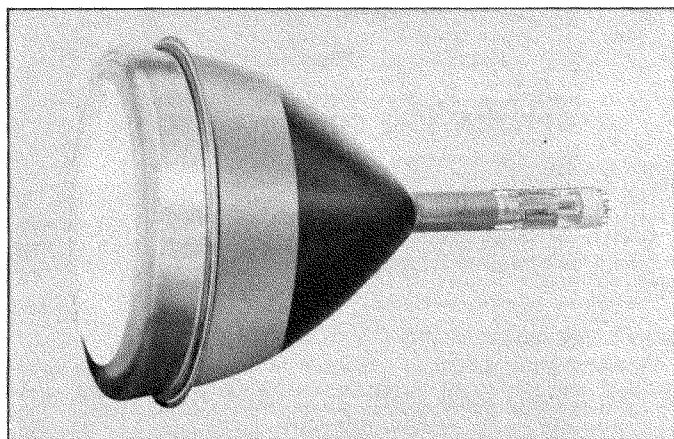

Fig. 1. The CBS-Colortron Type 15HP22

The CBS-Colortron is an aluminized, direct-view, tri-color picture tube designed for use in color-television receivers. Electromagnetically deflected and electrostatically focused, the CBS-Colortron has a deflection angle of 45 degrees, and an over-all length of 26 1/8 inches. It provides a choice of full-color or black-and-white pictures on a screen area of approximately 116 square inches.

This tube employs an all-glass construction and incorporates a unique mask-and-screen assembly. The simplicity of this assembly facilitates the use of low-cost mass-production techniques, and enhances the operational quality of the tube.

ELECTRON-GUN ASSEMBLY

The electron-gun assembly contains three matched, electrostatic-focus electron guns, each similar to the gun used in the 5TP4 projection-type black-and-white tube. The three guns are arranged in a triangular configuration, with each gun aligned parallel to and equidistant from the tube axis. The guns are also displaced from each other by an angle of 120°, measured in a plane perpendicular to the tube axis.

PHOSPHOR SCREEN AND APERTURE MASK

By a unique method of screen processing, the tri-color, phosphor-dot screen is placed directly on the inside surface of the spherical face plate of the CBS-Colortron. In addition to achieving simple construction and high-quality reproduction, many electrical and structural advantages are realized, because of this advanced design. Dynamic focusing and convergence requirements are reduced to a minimum; sharper, brighter pictures result; adjustment time is reduced to a minimum; and a simple, stable over-all tube construction is attained.

The phosphor screen of the CBS-Colortron contains some 250,000 phosphor dots of each primary color, a total of 750,000 phosphor dots. These dots are arranged in 250,000 triangular groups, or triads. Each triad contains one red, one blue, and one green phosphor dot.

Another component of the CBS-Colortron is the aperture mask. See Figure 2. This thin, arched mask is located between the phosphor screen and the electron-gun assembly. It contains approximately 250,000 round holes, one for each triad on the screen. Since the position of these holes relative to the triads is of paramount importance for proper tube operation, the mask is accurately positioned with relation to the triads and is approximately 0.4 inch behind the phosphor screen. Figure 3, graphically illustrates the orientation of the holes in the mask with the triads on the screen.

MASK-AND-SCREEN ASSEMBLY

As can be seen in Figure 2, the entire mask assembly is the ultimate in simplicity. It consists of the curved mask with spring clips to hold it in place. This assembly is mounted on three

hemispheres, which are raised points of glass molded around the edge of the face plate, beyond the picture area.

The mask contains three "V"-shaped surfaces which rest over the hemispheres and make use of the kinematic principle of precise location. Since the mask is unstressed, it is free to expand and contract. This combination of a curved face plate and a curved, unstressed mask automatically permits expansion and contraction without misregistration.

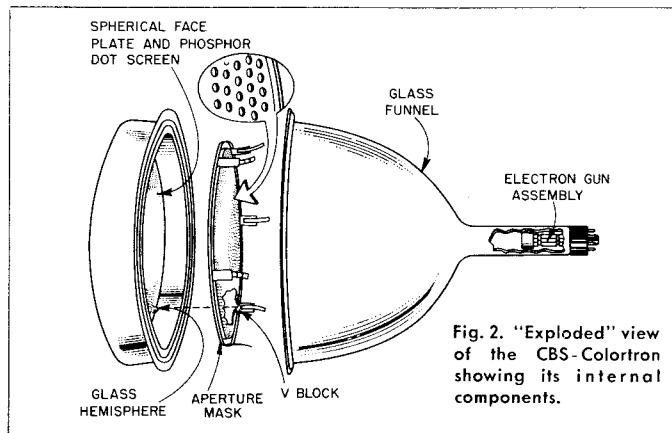

Fig. 2. "Exploded" view of the CBS-Colortron showing its internal components.

PRINCIPLES OF TUBE OPERATION

A logical starting point to discuss tube operation is the electron gun. As was previously stated, the CBS-Colortron contains three identical electron guns arranged in a triangular configuration. It follows that the resultant beams are also in the same triangular arrangement relative to the tube axis.

Each of these beams is individually modulated by a composite voltage that consists of color and brightness information. This voltage is applied to the control grid of the gun. In addition, a common d-c restorer voltage is simultaneously applied to all cathodes. By utilizing a separate composite signal for each gun, the individual beams are modulated in accordance with the transmitted signal, and are of the proper intensities for their respective colors.

The modulated beams are also focused by their respective guns. This focusing, similar to that in conventional black-and-white tubes, is accomplished by the electrostatic lens formed by grids 2 and 3. Since the focusing electrodes (grid 3 of each of the three guns) are internally connected together, a common focusing voltage may be used. This feature simplifies the associated circuitry.

As the three electron beams emerge from the convergence electrode (grid 4), they are acted upon by the electrostatic convergence lens. This lens is formed by the potential gradient that exists between the convergence electrode and the inner conductive coating in the neck of the tube. This conductive coating is electrically part of the accelerating anode. It is the function of this lens to converge the three beams at the aperture mask. Convergence is necessary to insure that the three color images will be superimposed.

Adjustment of convergence is accomplished by varying the voltage applied to the convergence electrode. This voltage is a combination of a static voltage and a dynamic voltage derived from the horizontal- and vertical-deflection circuits. It varies the focal length of the convergence lens in accordance with the position of the beams as they scan the phosphor screen. The spherical shape of the mask and screen of the CBS-Colortron reduces the dynamic-convergence voltage and facilitates easy convergence adjustment in the receiver.

PREPARED BY COMMERCIAL ENGINEERING DEPT.

CBS-HYTRON

A Division of Columbia Broadcasting System, Inc.
DANVERS, MASSACHUSETTS

Bulletin #E-222
January 25, 1954

In the ideal case, the three beams leave the convergence lens so aligned that, when deflected, they approach the aperture mask at the correct angles properly converged. In the practical case, however, this is not always true. For this reason, it is necessary to employ external components to align properly the three beams.

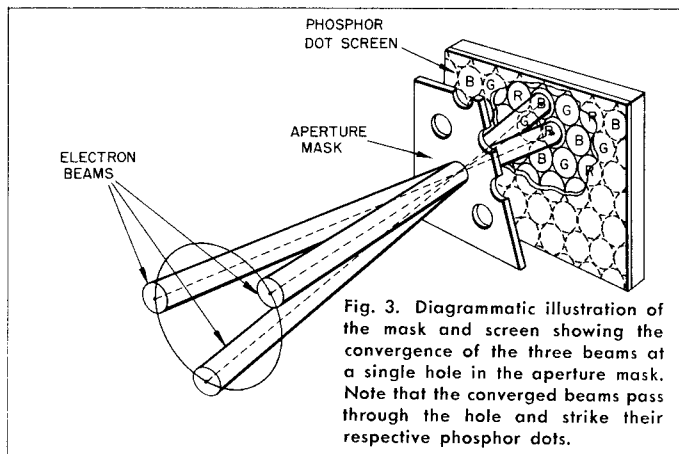

Fig. 3. Diagrammatic illustration of the mask and screen showing the convergence of the three beams at a single hole in the aperture mask. Note that the converged beams pass through the hole and strike their respective phosphor dots.

The first of these external components is a combination of three small, moveable permanent magnets, one for each beam. These magnets provide for adjustment of each of the beams, so that they will be properly acted upon by the convergence lens. The three magnets are mounted nominally 120° apart on the circumference of a non-ferrous ring. The ring is located approximately 1½ inches from the tube axis in the grid-No. 2 region.

The other external component necessary for proper beam alignment is the color-purifying coil. The magnetic field produced by this coil is perpendicular to the tube axis. This field acts upon the three beams simultaneously and, by proper adjustment of its strength, and its axial and rotational position, the common axis of three beams can be positioned to achieve optimum color purity. The coil is located on the neck of the tube in the region of grids 2 and 3. The construction of the coil should allow it to be rotated and moved along the neck of the tube.

After the beams have been acted upon by the alignment components and the convergence lens, they enter the deflection area. Here, the deflection yoke provides the required uniform magnetic fields that simultaneously deflect the three beams.

As in black-and-white tubes, the deflection yoke consists of four electromagnetic coils. These coils function in pairs, each coil of a pair located diametrically opposite the other. Since this deflection yoke acts simultaneously on three beams, the electromagnetic field requirements are more stringent than those in black-and-white tubes. In particular, a more uniform field is required for deflection in the tri-color tube.

The electron beams travel in straight line paths from the deflection area to the screen, as seen in Figure 3. Between the phosphor screen and the deflection area is the aperture mask. This mask is positioned so that, when viewed from the deflection point of any of the beams, only the dots of a single color can be seen through the perforations in the mask. Figure 4 illustrates this condition.

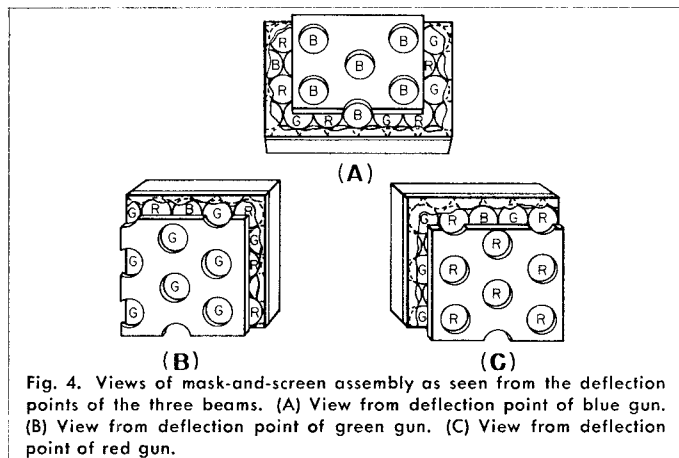

Fig. 4. Views of mask-and-screen assembly as seen from the deflection points of the three beams. (A) View from deflection point of blue gun. (B) View from deflection point of green gun. (C) View from deflection point of red gun.

With the mask in the position described above, one beam will strike only the red dots, another beam will strike only blue dots, and the third beam will strike only green dots. This mask, consequently, allows the three beams to reproduce the exact hue present in each portion of the televised scene.

APPLICATION CONSIDERATIONS

TUBE HANDLING

The CBS-Colortron should never be lifted by its neck alone. It is recommended that the tube be lifted by the glass bulb and neck, or by the bulb alone. Special care should be taken to avoid striking or otherwise damaging the metal flange near the face plate of the tube.

COVER FOR FACE PLATE

A safety glass should be mounted in front of the tube when installed in a television cabinet to provide protection against accidental striking of the face plate and possible tube implosion. This precaution is similar to conventional black-and-white tube requirements.

SUPPORT

Supports for the CBS-Colortron, which weighs approximately 18½ pounds, should be in the form of an insulated support at the large end of the tube and another near the small end of the bulb. Support for this tube should never be provided at the neck of the tube. Since the deflection yoke must be free to move in an axial and transverse direction, tube supports in this area are also not advisable.

HIGH-VOLTAGE REQUIREMENTS

Briefly stated, the high-voltage requirements of the CBS-Colortron are: anode, 20,000 volts with a maximum current drain of 600 microamperes; convergence electrode, 9,300 volts with a maximum drain of 5 microamperes; and focus electrode, 3,100 volts with a maximum current drain of 300 microamperes. In addition, the regulation of the anode and convergence voltages must be maintained within two percent to prevent misregistration.

The regulated voltages for the convergence electrode and anode may be derived from a flyback-type deflection system that employs a tapped autotransformer. These voltages are obtained from the full winding of the autotransformer. A separate tap of the same autotransformer supplies the voltage to the focus rectifier tube.

Since two-percent regulation is required for the anode and convergence voltage supply, a shunt regulator or corona discharge tube should be employed.

Adjustment of the focus and convergence potentials can be achieved by the use of potentiometers in the high-voltage divider network.

COLOR-PURIFYING COIL

The function of this coil has been described in a preceding section. The approximate position of the coil on the neck of the tube is shown in Figure 5. By rotating the coil around the neck of the tube, the transverse magnetic field will move the beams in different directions. The current through the coil determines the magnitude of the movement. A typical coil requires a current source capable of supplying from 0 to 200 milliamperes. Sickles No. 17086-1 color-purifying coil or equivalent is recommended for use with the 15HP22.

BEAM-POSITIONING MAGNETS

The function and description of this assembly has also been described in a preceding section. Figure 5 illustrates the position of these magnets on the neck of the tube. The field strength of each magnet is approximately 8 gauss. Sickles No. 17086-1 beam-positioning magnets or equivalent are recommended for use with the 15HP22.

DEFLECTION YOKE

The deflection yoke recommended for use with the 15HP22 is Sickles No. 17080-1 or equivalent. To permit adjustment for color purity, the deflection yoke, when placed against the glass funnel, should be capable of being moved two inches toward the tube base.

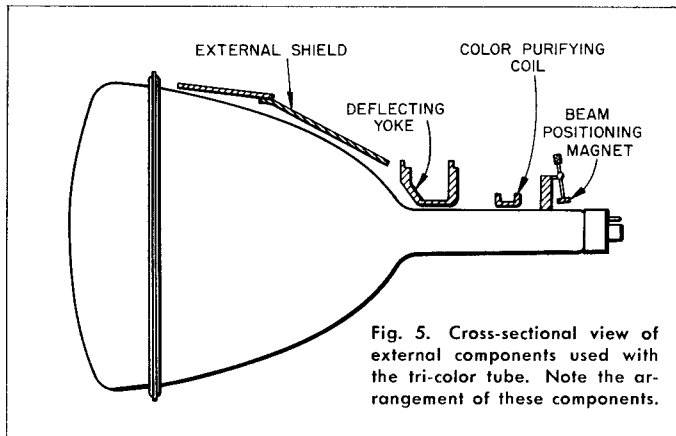

Fig. 5. Cross-sectional view of external components used with the tri-color tube. Note the arrangement of these components.

GRID NO. 1 DRIVE CHARACTERISTICS AND REQUIREMENTS

The three electron guns of the CBS-Colortron have similar transfer characteristics. Due to the differences in phosphor luminescence efficiencies, however, the cutoff voltage of each gun must be adjusted to produce equal phosphor brightness or color balance. If color balance is not maintained when the tube is reproducing black-and-white pictures, for instance, color tinting of the gray scale will result. It is recommended that individual grid-No. 2 voltage controls and grid-No. 1 drive controls be provided. The grid-No. 2 controls should allow voltage adjustment from 100 to 450 volts.

PROTECTION AGAINST SCANNING FAILURE

Permanent damage may be done to the screen-and-mask assembly if scanning should cease during tube operation. For this reason, an electronic switch activated by the horizontal and vertical deflection voltages should be provided. The circuit should be arranged so that, in case of scanning failure, all beam current will be cut off.

A convenient method of achieving this protection is by obtaining the grid-No. 2 voltages from the boost voltage of the horizontal scanning circuit. This boost voltage also serves to power the vertical deflection system. Any failure of scanning, consequently, would remove the voltage from the No. 2 grids, and all beam current would cease.

MAGNETIC SHIELDING

Optimum performance of the CBS-Colortron necessitates proper shielding against the effects of the earth's magnetic field and stray fields around the picture tube. A magnetic shield of MuMetal or equivalent material should be placed over the bulb portion of the tube. Placement of magnetic components of the receiver so that the effect of their fields on the picture tube is minimized will result in improved tube performance.

INSTALLATION AND ADJUSTMENT PROCEDURE

By following a systematic adjustment procedure, adjustment time of the CBS-Colortron can be reduced to a minimum. Such a procedure is described in this section. In addition to the procedural steps, screen patterns that will be observed during each step are described.

When the CBS-Colortron is removed from its carton, it should be handled by the bulb and not by the neck of the tube. Care should be taken to prevent damage to the metal flange near the face plate of the tube. The tube should be mounted securely in the manner described in the SUPPORT Section of this bulletin.

After mounting, the color-purity coil, convergence magnets, and deflection yoke should be placed on the neck of the tube. The approximate position of each of these components is described in the APPLICATION CONSIDERATIONS Section of this bulletin.

Also, refer to Figure 5 for a graphic illustration of these external components. Once these components are positioned on the neck of the tube, the socket and high-voltage connections may be made.

Before applying voltages to the tube, turn the grid-No. 2 controls to zero and the grid-No. 1 controls to their maximum negative positions. Then, apply the proper potentials to the electrodes of the tube, and sweep power to the deflection yoke. Initially, some arcing or sputtering may be observed. This is a normal reaction.

After allowing sufficient time for the various supplies to stabilize, slowly increase the grid-No. 2 voltage of the red gun, simultaneously reducing the grid-No. 1 bias until the screen is illuminated.

The next step is to adjust the purity coil. This adjustment should be made in the following steps:

1. Pull the deflection yoke back from the funnel of the tube approximately 2 inches.
2. Energize the color-purity coil.
3. Move the purity coil along the neck of the tube, while simultaneously rotating it and varying the current through it, until the purest red field is obtained in the center of the screen. It will be noted that the pattern on the screen also contains alternate blue and green fields extending radially out from this red center.
4. Slide the deflection yoke in the direction of the face plate until the most uniform red field is obtained over the entire screen.

Once the most uniform red field is obtained, slight readjustment of the color purity coil may be required to achieve optimum color purity. The adjustment may be made by varying the current through the purity coil or by additional movement of the coil.

After obtaining optimum purity of the red field, the blue and green fields should be separately checked. No further adjustment of the color purity coil should be necessary.

Convergence is the next characteristic to be adjusted. This adjustment procedure must be made in two separate parts. Convergence adjustment is facilitated by use of a spot generator. This spot generator should be capable of producing equally spaced horizontal and vertical rows of spots on the phosphor screen. Each of these spots contains individual red, blue, and green components. Proper convergence is attained when the three color components are superimposed.

Initially, the static convergence voltage is adjusted so that spots near the center portion of the screen are converged. If this condition is not obtained, the beam-positioning magnets should be adjusted until the spots within a small central area of the screen are converged.

Dynamic convergence can be optimized after the static convergence is attained. Horizontal dynamic convergence is obtained by adjustment of the waveform and amplitude of the horizontal-dynamic-convergence voltage. This voltage should be varied until each spot of a horizontal row near the center of the screen is converged. Vertical convergence is attained by varying the vertical-dynamic-convergence voltage until each spot of a vertical row near the center of the screen is converged. Because of the interaction between the horizontal- and vertical-convergence adjustments, it is recommended that these adjustments be performed alternately until optimum convergence is obtained.

The final adjustment of the CBS-Colortron is the setting of the color balance. As was previously stated, the transfer characteristics and bias voltages of the three guns must be adjusted to produce a grey scale with no color tinting.

The following steps should be taken to achieve color balance.

1. Set each grid-No. 2 voltage at the same value.
2. Set each grid-No. 1 voltage so that a low-level grey field is obtained on the screen.
3. Increase the brightness level of the composite field on the screen. This may be done by varying a master brightness control, or by varying a signal voltage simultaneously applied to all No. 1 grids.
4. As the brightness is increased during Step 3, observe which color becomes dominant.
5. Reduce the brightness of the field to the level in Step 2.
6. Reduce the grid-No. 2 voltage of the gun controlling the dominant color.
7. Repeat steps 3 through 6 until no color tinting is observed over the required brightness range.

This color-balancing procedure can be simplified by the use of a combination of a density wedge and flying-spot scanner.

The foregoing adjustment procedure represents the method that achieves the fastest alignment consistent with optimum operational quality. After these steps have been completed, further adjustment should not be required. But further adjustment of the various components can be made to overcome any undesirable characteristics that may result from improper initial adjustment.

DATA ON TYPE 15HP22

GENERAL CHARACTERISTICS

Electrical Data

Heater for unipotential cathode, each gun*			
Voltage	6.3	volts	
Current	1.8	amperes	
Focusing method	Electrostatic		
Convergence method	Electrostatic		
Deflection method	Magnetic		
Deflection angle (approximate)	45 degrees		
Electron guns, three	Red, Blue, Green		
Phosphor JETEC Designation P22			
Fluorescence	Red	Blue	Green
Phosphorescence	Red	Blue	Green
Persistence	Medium	Medium	Medium
Direct interelectrode capacitances (approximate):			
Grid No. 1 of any gun to all other electrodes except No. 1 grids of other two guns	7.5 uuf		
Three cathodes externally tied together to all other electrodes	17.5 uuf		
Grid No. 3 (all three No. 3 grids tied together internally) to all other electrodes	12.0 uuf		
Grid No. 4 (common to all three guns) to all other electrodes	7.0 uuf		
External conductive coating	.1500 uuf min. 2500 uuf max.		
Screen	Metal-backed, tri-color, phosphor-dot type		
Phosphor-dot arrangement	Approximately 250,000 triangular groups, each containing a blue, red, and green dot (a total of 750,000 dots)		

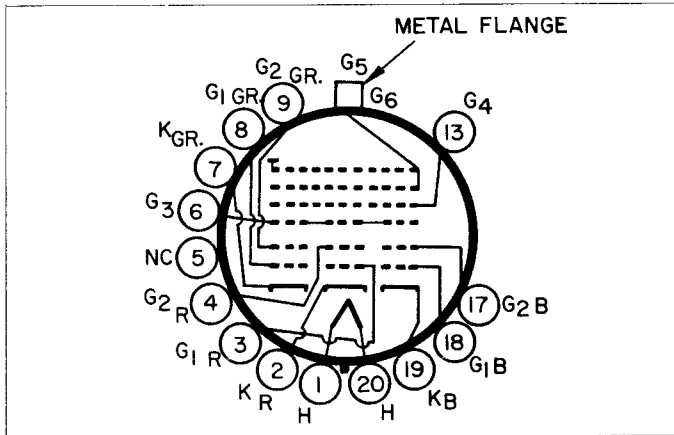

Basing Diagram

Pin 1: Heater	Pin 8: Grid No. 1 of green gun
Pin 2: Cathode of red gun	Pin 9: Grid No. 2 of green gun
Pin 3: Grid No. 1 of red gun	Pin 13: Grid No. 4
Pin 4: Grid No. 2 of red gun	Pin 17: Grid No. 2 of blue gun
Pin 5: No connection	Pin 18: Grid No. 1 of blue gun
Pin 6: Grids No. 3	Pin 19: Cathode of blue gun
Pin 7: Cathode of green gun	Pin 20: Heater

Metal Flange: Anode

Mechanical Data

Approximate weight	18½ pounds
Maximum over-all length	26⅞ inches
Maximum diameter	15¾ inches
Minimum screen diameter	12 inches
Bulb Contact	Metal-flange seal
Base	Small-shell bidecal 14-pin JETEC No. B14-103
Mounting position	Any
Socket	Cinch No. 57C17902 or equivalent
Horizontal output transformer	Sickles No. 17081-1 or equivalent
Purity coil and beam-positioning magnets	Sickles No. 17086-1 or equivalent
Deflection yoke	Sickles No. 17080-1 or equivalent

MAXIMUM RATINGS — Design-Center Values

Anode voltage	20,000 volts d-c
Grid-No. 4 (convergence) voltage	11,000 volts
Grid-No. 3 (focus) voltage	5,000 volts
Grid-No. 2 (accelerating) voltage, each gun	500 volts d-c
Grid-No. 1 (control) voltage, each gun	
Negative-bias value	200 volts d-c
Positive-bias value	0 volts d-c
Positive-peak value	2 volts
Peak heater-cathode voltage, each gun:	
Heater negative with respect to cathode:	
During warm-up period not to exceed 15 seconds	410 volts
After warm-up	180 volts
Heater positive with respect to cathode	180 volts

TYPICAL OPERATING CONDITIONS

Anode voltage	20,000 volts
Grid-No. 4 (convergence) voltage, approximate**	9,300 volts
Grid-No. 3 (focus) voltage, approximate	3,100 volts
With grid-No. 2 voltage of 200 volts, each gun	
Grid-No. 1 voltage [‡] , each gun	—45 to —100 volts
With grid-No. 1 voltage of —75 volts, each gun	
Grid-No. 2 voltage, each gun	240 volts
Maximum grid-No. 4 current	.5 microamperes
Maximum peak grid-No. 3 current	.300 microamperes

CIRCUIT VALUES

Maximum grid-No. 1 circuit resistance, each gun 1.5 megohms
 Horizontal-dynamic-convergence voltage, approximate^{‡‡} 550 volts
 Vertical-dynamic-convergence voltage, approximate^{‡‡} 200 volts
 Dynamic-focus voltage, approximate^{‡‡} 150 volts
 *Heaters electrically paralleled within the tube.
 **Does not include the a-c component of the convergence voltage.
 †For visual extinction of focused raster.
 ‡‡Peak-to-peak value. This a-c voltage is synchronized with the scanning and does not include any voltage developed during the blanking time.
 To reduce the effects of stray magnetic fields on color purity, a magnetic shield is recommended. This shield should fit snugly around the cone of the glass bulb. Outline drawing of a recommended shield is shown elsewhere in this bulletin.

CAUTION

Because the rating of this tube permits operation at voltages as high as 20,000 volts, shielding of the tube for X-ray radiation may be necessary whenever operating conditions involve voltages in excess of 16,000 volts. Sufficient shielding is usually provided by the safety glass in front of the tube.

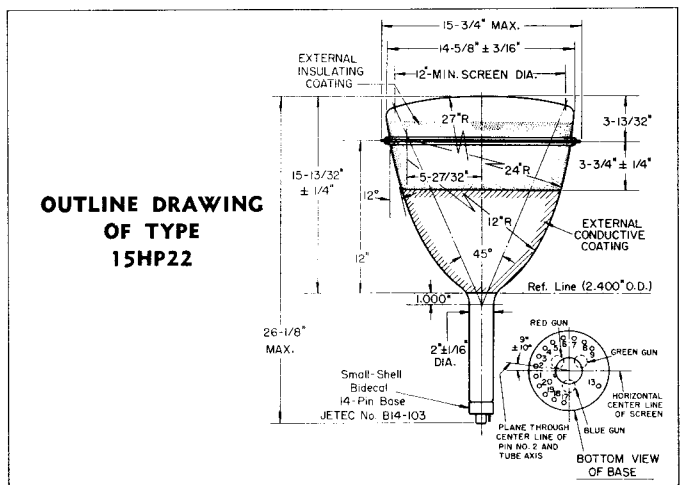

OUTLINE DRAWING OF TYPE 15HP22

MAGNETIC SHIELD RECOMMENDED FOR USE WITH 15HP22

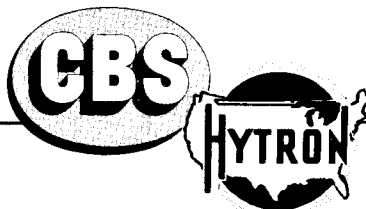
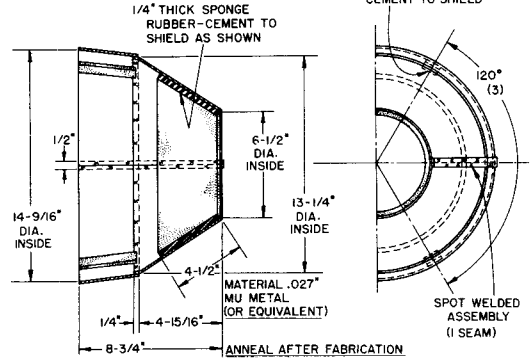

CBS-HYTRON Main Office: Danvers, Massachusetts

A Division of Columbia Broadcasting System, Inc.

A MEMBER OF THE CBS FAMILY: CBS Radio • CBS Television • Columbia Records, Inc. CBS Laboratories • CBS-Columbia • and CBS-Hytron