



# 80960RM I/O Processor

- Complies with PCI Local Bus Specification, Revision 2.1
- 5 V, PCI Signalling Environment

## Data Sheet

---

## Advance Information

### Product Features

- High Performance 80960JT Core
  - Sustained One Instruction/Clock Execution
  - 16 Kbyte, Two-Way Set-Associative Instruction Cache
  - 4 Kbyte, Direct-Mapped Data Cache
  - Sixteen 32-Bit Global Registers
  - Sixteen 32-Bit Local Registers
  - 1 Kbyte, Internal Data RAM
  - Local Register Cache (Eight Available Stack Frames)
  - Two 32-Bit On-Chip Timer Units
- PCI-to-PCI Bridge Unit
  - 8 Delayed Read/Write Buffers Holding up to 8 Transactions
  - Primary and Secondary 32-bit PCI Interfaces
  - Two Posting Buffers Holding up to 12 Transactions
  - Delayed and Posted Transaction Support
  - Forwards Memory, I/O, Configuration Commands from PCI Bus to PCI Bus
- I<sub>2</sub>O Messaging Unit
  - Four Message Registers
  - Two Doorbell Registers
  - Four Circular Queues
  - 1004 Index Registers
- Memory Controller
  - 128 Mbytes of 64-Bit SDRAM or 64 Mbytes of 32-Bit SDRAM
  - ECC Single-Bit error correction, Double-Bit error detection
  - Two Independent Banks for SRAM / ROM / Flash (8 Mbytes/Bank; 8-Bit)
- Two Address Translation Units
  - Connects Internal Bus to 32-bit PCI Buses
  - Inbound/Outbound Address Translation Support
  - Direct Outbound Addressing Support
- DMA Controller
  - Three Independent Channels
  - PCI Memory Controller Interface
  - 64-Bit Internal + PCI Bus Addressing
  - Independent Interface to 32-bit Primary and Secondary PCI Buses
  - 132 Mbyte/sec Burst Transfers to PCI and Local Buses
  - Direct Addressing to/from PCI Buses
  - Unaligned Transfers Supported in Hardware
  - Two Channels Dedicated to Primary PCI Bus
  - One Channel Dedicated to Secondary PCI Bus
- I<sup>2</sup>C Bus Interface Unit
  - Serial Bus
  - Master/Slave Capabilities
  - System Management Functions
- Secondary PCI Arbitration Unit
  - Supports Six Secondary PCI Devices
  - Multi-priority Arbitration Algorithm
- Private PCI Device Support
- Perimeter Land Grid Array Package
  - 540-pin
- Application Accelerator
  - Built-in hardware XOR engine
- Performance Monitoring
  - 98 events monitored on-chip

---

**Notice:** This document contains information on products in the sampling and initial production phases of development. The specifications are subject to change without notice. Verify with your local Intel sales office that you have the latest datasheet before finalizing a design.

---

Information in this document is provided in connection with Intel products. No license, express or implied, by estoppel or otherwise, to any intellectual property rights is granted by this document. Except as provided in Intel's Terms and Conditions of Sale for such products, Intel assumes no liability whatsoever, and Intel disclaims any express or implied warranty, relating to sale and/or use of Intel products including liability or warranties relating to fitness for a particular purpose, merchantability, or infringement of any patent, copyright or other intellectual property right. Intel products are not intended for use in medical, life saving, or life sustaining applications.

Intel may make changes to specifications and product descriptions at any time, without notice.

Designers must not rely on the absence or characteristics of any features or instructions marked "reserved" or "undefined." Intel reserves these for future definition and shall have no responsibility whatsoever for conflicts or incompatibilities arising from future changes to them.

The 80960RM I/O Processor may contain design defects or errors known as errata which may cause the product to deviate from published specifications. Current characterized errata are available on request.

Contact your local Intel sales office or your distributor to obtain the latest specifications and before placing your product order.

Copies of documents which have an ordering number and are referenced in this document, or other Intel literature may be obtained by calling 1-800-548-4725 or by visiting Intel's website at <http://www.intel.com>.

Copyright © Intel Corporation, 1997

\*Third-party brands and names are the property of their respective owners.

## Contents

---

<b>1.0</b>	<b>About this Document</b> .....	1
1.1	Solutions960 <sup>®</sup> Program.....	1
1.2	Terminology.....	1
1.3	Additional Information Sources .....	1
<b>2.0</b>	<b>Functional Overview</b> .....	2
2.1	Key Functional Units .....	3
2.1.1	PCI-to-PCI Bridge Unit .....	3
2.1.2	Private PCI Device Support.....	3
2.1.3	DMA Controller.....	3
2.1.4	Address Translation Unit .....	3
2.1.5	Messaging Unit.....	3
2.1.6	Memory Controller Unit .....	4
2.1.7	I2C Bus Interface Unit .....	4
2.1.8	Secondary PCI Arbitration Unit .....	4
2.1.9	Application Accelerator Unit .....	4
2.1.10	Performance Monitor Unit .....	4
2.1.11	Bus Interface Unit.....	4
2.2	i960 <sup>®</sup> Core Features (80960JT) .....	5
2.2.1	Burst Bus.....	6
2.2.2	Timer Unit.....	6
2.2.3	Priority Interrupt Controller .....	6
2.2.4	Faults and Debugging .....	6
2.2.5	On-Chip Cache and Data RAM .....	6
2.2.6	Local Register Cache .....	7
2.2.7	Test Features .....	7
2.2.8	Memory-Mapped Control Registers .....	7
2.2.9	Instructions, Data Types and Memory Addressing Modes .....	7
<b>3.0</b>	<b>Package Information</b> .....	9
3.1	Package Introduction.....	9
3.1.1	Functional Signal Definitions .....	9
3.1.1.1	SIGNAL PIN DESCRIPTIONS .....	10
3.1.2	540-Lead H-PBGA Package .....	19
3.2	Package Thermal Specifications .....	31
3.2.1	Thermal Specifications .....	31
3.2.1.1	Ambient Temperature.....	31
3.2.1.2	Case Temperature .....	31
3.2.1.3	Thermal Resistance .....	32
3.2.2	Thermal Analysis.....	32
3.3	Heat Sink Information .....	33
3.4	Vendor Information.....	34
3.4.1	Socket-Header Vendor.....	34
3.4.2	Burn-in Socket Vendor .....	34
3.4.3	Shipping Tray Vendor.....	34
3.4.4	Logic Analyzer Interposer Vendor .....	34
3.4.5	JTAG Emulator Vendor .....	34

<b>4.0</b>	<b>Electrical Specifications</b> .....	35
4.1	Absolute Maximum Ratings .....	35
4.2	VCC5REF Pin Requirements ( $V_{DIFF}$ ).....	36
4.3	VCCPLL Pin Requirements .....	36
4.4	Targeted DC Specifications .....	37
4.5	Targeted AC Specifications.....	38
4.5.1	Clock Signal Timings.....	38
4.5.2	PCI Interface Signal Timings.....	39
4.5.3	JN Core Interface Timings.....	40
4.5.4	SDRAM/Flash Interface Signal Timings .....	40
4.5.5	Boundary Scan Test Signal Timings .....	41
4.5.6	I2C Interface Signal Timings .....	42
4.6	AC Timing Waveforms .....	43
4.7	AC Test Conditions .....	45
<b>5.0</b>	<b>Device Identification on Reset</b> .....	46

## Figures

1	80960RM Functional Block Diagram.....	2
2	80960JT Core Block Diagram .....	5
3	540L H-PBGA Package Diagram (Top and Side View) .....	19
4	540L H-PBGA Package Diagram (Bottom View) .....	20
5	Thermocouple Attachment - A) No Heatsink / B) With Heatsink .....	31
6	VCC5REF Current-Limiting Resistor.....	36
7	V <sub>CCPLL</sub> Lowpass Filter .....	36
8	P_CLK, TCK, DCLKIN, DCLKOUT Waveform .....	43
9	T <sub>OV</sub> Output Delay Waveform.....	43
10	T <sub>OF</sub> Output Float Waveform .....	44
11	T <sub>JS</sub> and T <sub>IH</sub> Input Setup and Hold Waveform .....	44
12	I <sup>2</sup> C Interface Signal Timings.....	44
13	AC Test Load (all signals except SDRAM and Flash signals).....	45

## Tables

1	Related Documentation.....	1
2	Instruction Set .....	8
3	Pin Description Nomenclature.....	10
4	Memory Controller Signals .....	11
5	Primary PCI Bus Signals .....	14
6	Secondary PCI Arbiter Signals.....	15
7	Secondary PCI Bus Signals .....	16
8	JX Core Signals and Configuration Straps.....	17
9	I <sup>2</sup> C, JTAG, Core Signals .....	18
10	540-Lead H-PBGA Package — Signal Name Order .....	21
11	540-Lead H-PBGA Pinout — Ballpad Number Order.....	26
12	540-Lead H-PBGA Package Thermal Characteristics .....	32
13	Heat Sink Vendors and Contacts .....	33
14	Socket-Header Vendor.....	34
15	Burn-in Socket Vendor .....	34
16	Shipping Tray Vendor.....	34
17	Logic Analyzer Interposer Vendor .....	34
18	JTAG Emulator Vendor .....	34
19	Operating Conditions.....	35
20	V <sub>DIFF</sub> Specification for Dual Power Supply Requirements (3.3 V, 5 V).....	36
21	DC Characteristics .....	37
22	I <sub>CC</sub> Characteristics .....	37
23	Input Clock Timings.....	38
24	SDRAM Output Clock Timings .....	38
25	PCI Signal Timings.....	39
26	JN Core Signal Timings.....	40
27	SDRAM / Flash Signal Timings .....	40
28	Boundary Scan Test Signal Timings .....	41
29	I2C Interface Signal Timings .....	42
30	Device ID Registers.....	46

## 1.0 About this Document

---

This is the Advance Information data sheet for the 80960RM processor. This data sheet contains a functional overview, mechanical data (package signal locations and simulated thermal characteristics), targeted electrical specifications (simulated), and bus functional waveforms. Detailed functional descriptions other than parametric performance is published in the *i960<sup>®</sup> RM/RN I/O Processor Developer's Manual*.

### 1.1 Solutions960<sup>®</sup> Program

Intel's *Solutions960<sup>®</sup>* program features a wide variety of development tools which support the i960 processor family. Many of these tools are developed by partner companies; some are developed by Intel, such as profile-driven optimizing compilers. For more information on these products, contact your local Intel representative.

### 1.2 Terminology

In this document, the following terms are used:

- *Primary and Secondary PCI buses* are the 80960RM processor's external PCI buses which conform to PCI SIG specifications.
- 80960 core refers to the 80960JT processor which is integrated into the 80960RM processor.

### 1.3 Additional Information Sources

Intel documentation is available from your local Intel Sales Representative or Intel Literature Sales.

Intel Corporation  
Literature Sales  
P.O. Box 5937  
Denver, CO 80217-9808  
1-800-548-4725

**Table 1. Related Documentation**

Document Title	Order / Contact
i960 <sup>®</sup> RP Microprocessor User's Guide	Intel Order # 272736
<i>i960<sup>®</sup> RP Processor: A Single-Chip Intelligent I/O Subsystem Technical Brief</i>	Intel Order # 272738
i960 <sup>®</sup> Jx Microprocessor User's Guide	Intel Order # 272483
<i>80960RP Specification Update</i>	Intel Order # 272918
<i>PCI Local Bus Specification, Revision 2.1</i>	PCI Special Interest Group 1-800-433-5177
<i>PCI-to-PCI Bridge Architecture Specification, Revision 1.0</i>	PCI Special Interest Group 1-800-433-5177
<i>PC Peripherals for Microcontrollers</i>	Philips Semiconductor
<i>Tuzigoot Microprocessor EAS</i>	Intel Order # AZ1-00824

## 2.0 Functional Overview

As indicated in [Figure 1](#), the 80960RM processor combines many features with the 80960JT to create an intelligent I/O processor. Subsections following the figure briefly describe the main features; for detailed functional descriptions, refer to the *i960<sup>®</sup> RM/RN I/O Processor Developer's Manual*.

The PCI bus is an industry standard, high performance, low latency system bus that operates up to 264 Mbyte/s. The 80960RM processor, a multi-function PCI device, is fully compliant with the *PCI Local Bus Specification, Revision 2.1*. Function 0 is the PCI-to-PCI bridge unit; Function 1 is the address translation unit.

The PCI-to-PCI bridge unit is the path between two independent 64-bit PCI buses and provides the ability to overcome PCI electrical load limits. The addition of the i960 core processor brings intelligence to the bridge.

The 80960RM processor, object code compatible with the i960 core processor, is capable of sustained execution at the rate of one instruction per clock.

The internal bus, a 64-bit PCI-like bus, is a high-speed interface to local memory and I/O. Physical and logical memory attributes are programmed via memory-mapped control registers (MMRs); an extension not found on the i960 Kx, Sx or Cx processors.

**Figure 1. 80960RM Functional Block Diagram**

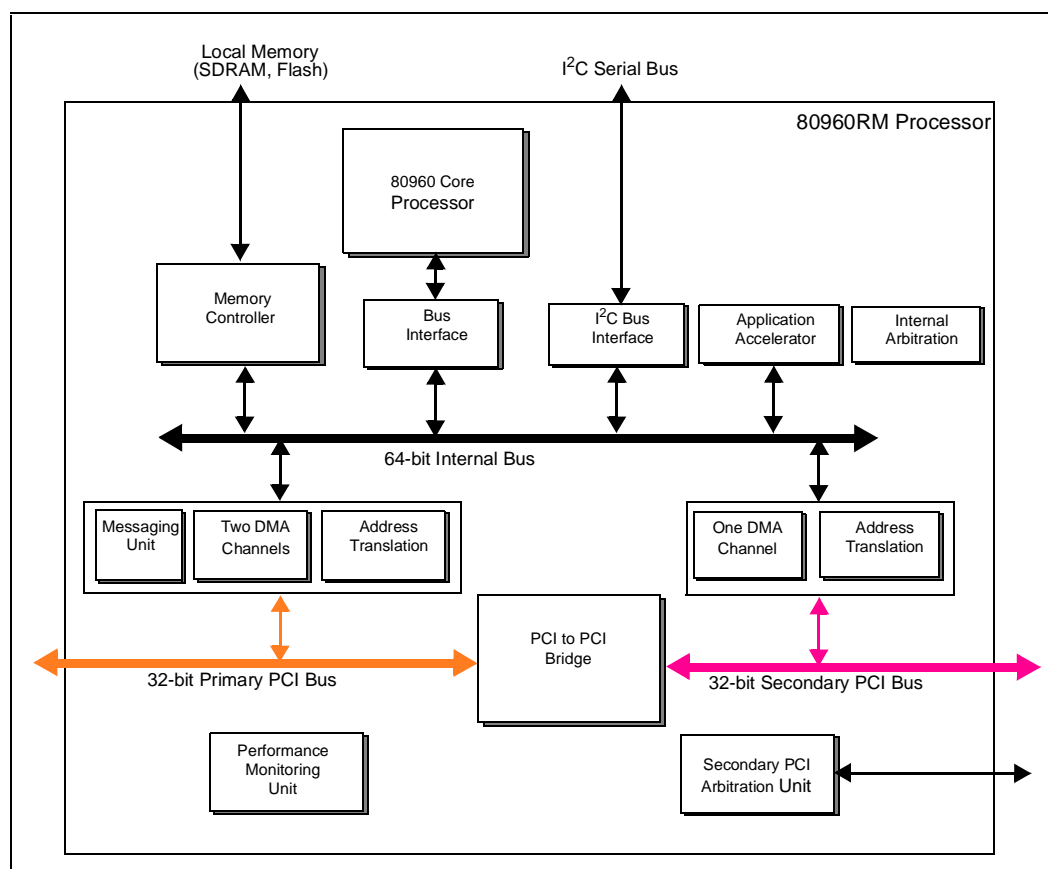

## 2.1 Key Functional Units

### 2.1.1 PCI-to-PCI Bridge Unit

The PCI-to-PCI bridge unit (referred to as “bridge”) connects two independent PCI buses. Each PCI bus is 32 bits wide. The bridge is fully compliant with the *PCI-to-PCI Bridge Architecture Specification*, Revision 1.0 published by the PCI Special Interest Group. The bridge forwards bus transactions on one PCI bus to the other PCI bus. Dedicated data queues support high performance bandwidth on the PCI buses. The 80960RM supports PCI 64-bit Dual Address Cycle (DAC) addressing.

The bridge has dedicated PCI configuration space accessible through the primary PCI bus.

### 2.1.2 Private PCI Device Support

The 80960RM processor explicitly supports private PCI devices on the secondary PCI bus. The bridge and Address Translation Unit work together to hide private PCI devices from PCI configuration cycles and allow these hidden devices to use a private PCI address space. The Address Translation Unit issues PCI configuration cycles to configure hidden devices.

### 2.1.3 DMA Controller

The DMA Controller supports low-latency, high-throughput data transfers between PCI bus agents and local memory. Three separate DMA channels accommodate data transfers: two for primary PCI bus, one for the secondary PCI bus. The DMA Controller supports chaining and unaligned data transfers. The DMA Controller is programmable only through the i960 core processor.

### 2.1.4 Address Translation Unit

The Address Translation Unit (ATU) allows PCI transactions direct access to local memory. The 80960RM processor has direct access to both PCI buses. The ATU supports transactions between PCI address space and 80960RM processor address space.

Address translation is controlled through programmable registers accessible from both the primary PCI interface and the 80960 core. Dual access to registers allows flexibility in mapping the two address spaces.

### 2.1.5 Messaging Unit

The Messaging Unit (MU) provides data transfer between the PCI system and the 80960RM processor. The Messaging Unit uses interrupts to notify the PCI system or the 80960RM processor when new data arrives. The MU has four messaging mechanisms: Message Registers, Doorbell Registers, Circular Queues, and Index Registers. Each mechanism allows a host processor or external PCI device and the 80960RM processor to communicate through message passing and interrupt generation.



### 2.1.6 Memory Controller Unit

The Memory Controller Unit (MCU) allows direct control of a local SDRAM and Flash subsystem. The MCU features programmable chip selects, a wait state generator and Error Correction and Detection. With the ATU configuration registers, local memory can be configured as PCI addressable memory or private processor memory.

### 2.1.7 I<sup>2</sup>C Bus Interface Unit

The I<sup>2</sup>C (Inter-Integrated Circuit) Bus Interface Unit allows the 80960 core to serve as a master and slave device residing on the I<sup>2</sup>C bus. The I<sup>2</sup>C bus is a serial bus developed by Philips Semiconductor comprising a two pin interface. The bus allows the 80960RM processor to interface to other I<sup>2</sup>C peripherals and microcontrollers for system management functions. It requires a minimum of hardware for an economical system to relay status and reliability information on the I/O subsystem to an external device. For more information, see *I<sup>2</sup>C Peripherals for Microcontrollers* (Philips Semiconductor).

### 2.1.8 Secondary PCI Arbitration Unit

The Secondary PCI Arbitration Unit provides PCI arbitration for the secondary PCI bus. The arbitration includes a fairness algorithm with programmable priorities and six external PCI Request and Grant signal pairs.

### 2.1.9 Application Accelerator Unit

The Application Accelerator Unit (AAU) provides hardware acceleration of XOR functions commonly used in RAID algorithms. Additionally, the AAU provides block moves within local memory. The Application Accelerator interfaces the internal bus and operates on data within local memory. The AAU is programmable through the i960 core processor and supports chaining and unaligned data transfers.

### 2.1.10 Performance Monitor Unit

The Performance Monitor Unit (PMU) allows software to monitor the performance of the different buses: Primary PCI, Secondary PCI, and Internal. Multiple performance characteristics are captured with 14 mode registers and a global time stamp register.

### 2.1.11 Bus Interface Unit

The Bus Interface Unit (BIU) provides an interface between the 100 MHz 80960JT core and the 66 MHz internal bus. To optimize performance, the BIU implements prefetching and write merging.

## 2.2 i960<sup>®</sup> Core Features (80960JT)

The processing power of the 80960RM processor comes from the 100 MHz 80960JT processor core. The 80960JT is a scalar implementation of the 80960 Core Architecture. Figure 2 shows a block diagram of the 80960JT Core processor.

Factors that contribute to the 80960JT core's performance include:

- 100 MHz Single-clock execution of most instructions
- Independent Multiply/Divide Unit
- Efficient instruction pipeline minimizes pipeline break latency
- Register and resource scoreboarding allow overlapped instruction execution
- 128-bit register bus speeds local register caching
- 16 Kbyte, two-way set-associative, integrated instruction cache
- 4 Kbyte direct-mapped, integrated data cache
- 1 Kbyte integrated data RAM delivers zero wait state program data

The 80960 core operates out of its own 32-bit address space, which is independent of the PCI address space. Local memory can be:

- Made visible to the PCI address space
- Kept private to the 80960JT core
- Allocated as a combination of the two

Figure 2. 80960JT Core Block Diagram

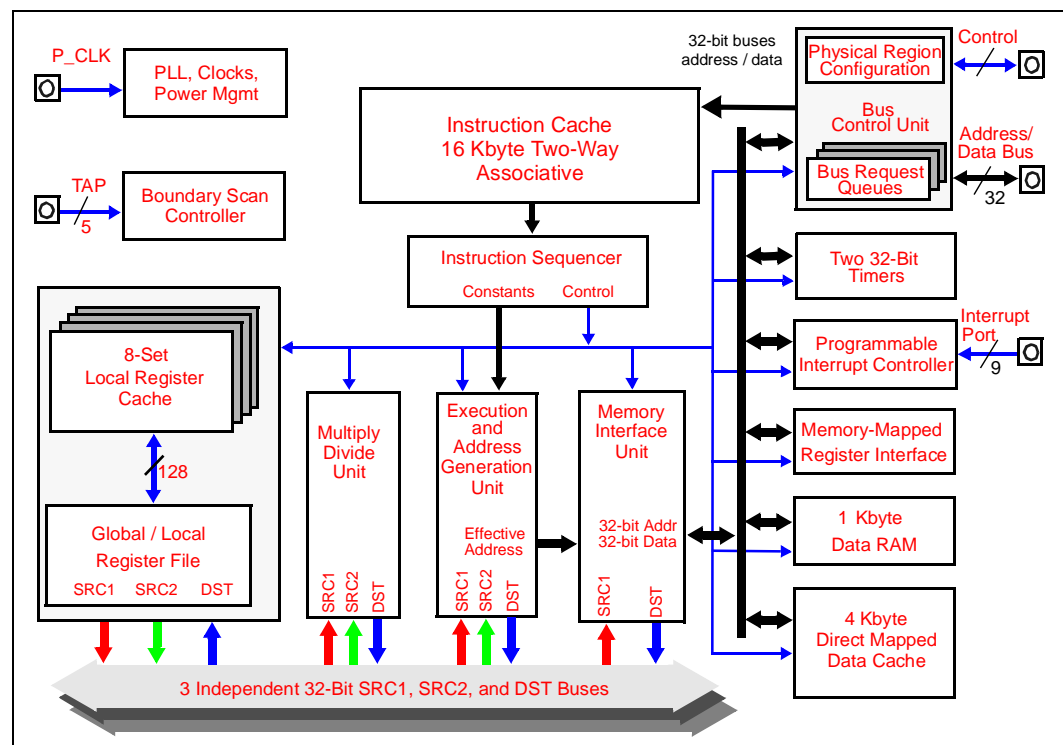

### 2.2.1 Burst Bus

A 32-bit high-performance bus controller interfaces the 80960RM processor to the Bus Interface Unit. The Bus Control Unit fetches instructions and transfers data on the internal bus at the rate of up to four 32-bit words per six clock cycles. The external address/data bus is multiplexed.

Data caching is programmed through a group of logical memory templates and a defaults register. The Bus Control Unit's features include:

- Multiplexed external bus minimizes pin count
- External ready control for address-to-data, data-to-data and data-to-next-address wait state types
- Little endian byte ordering
- Unaligned bus accesses performed transparently
- Three-deep load/store queue decouples the bus from the 80960 core

Upon reset, the 80960JT conducts an internal self test. Before executing its first instruction, it performs an external bus confidence test by performing a checksum on the first words of the Initialization Boot Record.

### 2.2.2 Timer Unit

The timer unit (TU) contains two independent 32-bit timers that are capable of counting at several clock rates and generating interrupts. Each is programmed through the Timer Unit registers. These memory-mapped registers are addressable on 32-bit boundaries. The timers have a single-shot mode and auto-reload capabilities for continuous operation. Each timer has an independent interrupt request to the 80960JT's interrupt controller. The TU can generate a fault when unauthorized writes from user mode are detected.

### 2.2.3 Priority Interrupt Controller

Low interrupt latency is critical to many embedded applications. As part of its highly flexible interrupt mechanism, the 80960JT exploits several techniques to minimize latency:

- Interrupt vectors and interrupt handler routines can be reserved on-chip
- Register frames for high-priority interrupt handlers can be cached on-chip
- The interrupt stack can be placed in cacheable memory space

### 2.2.4 Faults and Debugging

The 80960JT employs a comprehensive fault model. The processor responds to faults by making implicit calls to a fault handling routine. Specific information collected for each fault allows the fault handler to diagnose exceptions and recover appropriately.

The processor also has built-in debug capabilities. With software, the 80960JT may be configured to detect as many as seven different trace event types. Alternatively, **mark** and **fmark** instructions can generate trace events explicitly in the instruction stream. Hardware breakpoint registers are also available to trap on execution and data addresses.

### 2.2.5 On-Chip Cache and Data RAM

Memory subsystems often impose substantial wait state penalties. The 80960JT integrates considerable storage resources on-chip to decouple CPU execution from the external bus. The 80960JT includes a 16 Kbyte instruction cache, a 4 Kbyte data cache and 1 Kbyte data RAM.

### 2.2.6 Local Register Cache

The 80960JT rapidly allocates and deallocates local register sets during context switches. The processor needs to flush a register set to the stack only when it saves more than seven sets to its local register cache.

### 2.2.7 Test Features

The 80960RM processor incorporates numerous features that enhance the user's ability to test both the processor and the system to which it is attached. These features include ONCE (On-Circuit Emulation) mode and Boundary Scan (JTAG).

The 80960JT provides testability features compatible with IEEE Standard Test Access Port and Boundary Scan Architecture (IEEE Std. 1149.1).

One of the boundary scan instructions, HIGHZ, forces the processor to float all its output pins (ONCE mode). ONCE mode can also be initiated at reset without using the boundary scan mechanism.

ONCE mode is useful for board-level testing. This feature allows a mounted 80960RM processor to electrically "remove" itself from a circuit board allowing system-level testing where a remote tester can exercise the processor system.

The test logic does not interfere with component or system behavior and ensures that components function correctly and the connections between various components are correct.

The JTAG Boundary Scan feature is an alternative to conventional "bed-of-nails" testing. Boundary Scan can examine connections that might otherwise be inaccessible to a test system.

### 2.2.8 Memory-Mapped Control Registers

The 80960JT is compliant with 80960 family architecture. Each memory-mapped, 32-bit register is accessed via memory-format instructions. The processor ensures that these accesses do not generate external bus cycles.

### 2.2.9 Instructions, Data Types and Memory Addressing Modes

As with all 80960 family processors, the instruction set supports several different data types and formats:

- Bit
- Bit fields
- Integer (8-, 16-, 32-, 64-bit)
- Ordinal (8-, 16-, 32-, 64-bit unsigned integers)
- Triple word (96 bits)
- Quad word (128 bits)

The 80960JT provides a full set of addressing modes for C and assembly:

- Two Absolute modes
- Five Register Indirect modes
- Index with displacement mode
- IP with displacement mode

Table 2 shows the available 80960JT instructions.

**Table 2. Instruction Set**

<b>Data Movement</b>	<b>Arithmetic</b>	<b>Logical</b>	<b>Bit, Bit Field and Byte</b>
Load Store Move Conditional Select Load Address	Add Subtract Multiply Divide Remainder Modulo Shift Extended Shift Extended Multiply Extended Divide Add with Carry Subtract with Carry Conditional Add Conditional Subtract Rotate	And Not And And Not Or Exclusive Or Not Or Or Not Nor Exclusive Nor Not Nand	Set Bit Clear Bit Not Bit Alter Bit Scan For Bit Span Over Bit Extract Modify Scan Byte for Equal Byte Swap
<b>Comparison</b>	<b>Branch</b>	<b>Call/Return</b>	<b>Fault</b>
Compare Conditional Compare Compare and Increment Compare and Decrement Test Condition Code Check Bit	Unconditional Branch Conditional Branch Compare and Branch	Call Call Extended Call System Return Branch and Link	Conditional Fault Synchronize Faults
<b>Debug</b>	<b>Processor Management</b>	<b>Atomic</b>	
Modify Trace Controls Mark Force Mark	Flush Local Registers Modify Arithmetic Controls Modify Process Controls Halt System Control Cache Control Interrupt Control	Atomic Add Atomic Modify	

## 3.0 Package Information

---

### 3.1 Package Introduction

The 80960RM processor is offered in a Perimeter Land Grid Array (PBGA) package. This is a perimeter array package with five rows of ball connections in the outer area of the package. See Figure 4 “540L H-PBGA Package Diagram (Bottom View)” on page 20.

#### 3.1.1 Functional Signal Definitions

This section defines the pins and signals in the following tables:

- Table 3 “Pin Description Nomenclature” on page 10
- Table 4 “Memory Controller Signals” on page 11
- Table 5 “Primary PCI Bus Signals” on page 14
- Table 6 “Secondary PCI Arbiter Signals” on page 15
- Table 8 “JX Core Signals and Configuration Straps” on page 17
- Table 9 “I<sup>2</sup>C, JTAG, Core Signals” on page 18

### 3.1.1.1 SIGNAL PIN DESCRIPTIONS

**Table 3. Pin Description Nomenclature**

SYMBOL	DESCRIPTION
I	Input pin only
O	Output pin only
I/O	Pin can be either an input or output
OD	Open Drain pin
-	Pin must be connected as described
N/C	NO CONNECT. <u>Do not</u> make electrical connections to these balls.
5V	Input pin is 5 volt tolerant
Sync(...)	Synchronous. Inputs meet setup and hold times relative to an input clock. Sync(P) Synchronous to <b>P_CLK</b> Sync(D) Synchronous to <b>DCLKIN</b> Sync(T) Synchronous to <b>TCK</b>
Async	Asynchronous. Inputs may be asynchronous relative to <b>P_CLK</b> , <b>DCLKIN</b> , or <b>TCK</b> . All asynchronous signals are level-sensitive.
Prst(...)	While the <b>P_RST#</b> pin is asserted, the pin: Prst(1) Is driven to $V_{CC}$ Prst(0) Is driven to $V_{SS}$ Prst(X) Is driven to unknown state Prst(H) Is pulled up to $V_{CC}$ Prst(L) Is pulled down to $V_{SS}$ Prst(Z) Floats Prst(Q) Is a valid output Since <b>P_RST#</b> is asynchronous, these are asynchronous events.
Srst(...)	While the <b>S_RST#</b> pin is asserted, the pin: Srst(1) Is driven to $V_{CC}$ Srst(0) Is driven to $V_{SS}$ Srst(X) Is driven to unknown state Srst(H) Is pulled up to $V_{CC}$ Srst(L) Is pulled down to $V_{SS}$ Srst(Z) Floats Srst(Q) Is a valid output Note that <b>S_RST#</b> is asserted when <b>P_RST#</b> is asserted or BCR[6] is set with software.
Irst(...)	While the <b>I_RST#</b> pin is asserted, the pin: Irst(1) Is driven to $V_{CC}$ Irst(0) Is driven to $V_{SS}$ Irst(X) Is driven to unknown state Irst(H) Is pulled up to $V_{CC}$ Irst(L) Is pulled down to $V_{SS}$ Irst(Z) Floats Irst(Q) Is a valid output Note that <b>I_RST#</b> is asserted when <b>P_RST#</b> is asserted or EBCR[5] is set with software.

Table 4. Memory Controller Signals (Sheet 1 of 3)

NAME	COUNT	TYPE	DESCRIPTION
DCLKOUT	1	$\bar{O}$ Irst(Q)	<b>SDRAM OUTPUT CLOCK</b> dedicated for SDRAM memory subsystem.
DCLKIN	1	I	<b>SDRAM INPUT CLOCK</b> dedicated for SDRAM memory subsystem. Used to skew DCLKOUT appropriately to accommodate flight time and clock buffer delays.
SA[11:0]	12	$\bar{O}$ Irst(Q)	<b>SDRAM MULTIPLEXED ADDRESS BUS</b> carries the multiplexed row and column addresses to the SDRAM memory banks. For SA[10], see note 1.
SBA[1:0]	2	$\bar{O}$ Irst(Q)	<b>SDRAM INTERNAL BANK SELECT</b> indicates which of the SDRAM internal banks are read or written during the current transaction.
SRAS#	1	$\bar{O}$ Irst(1)	<b>SDRAM ROW ADDRESS STROBE</b> indicates the presence of a valid row address on the Multiplexed Address Bus SA[11:0]. See note 1.
SCAS#	1	$\bar{O}$ Irst(1)	<b>SDRAM COLUMN ADDRESS STROBE</b> indicates the presence of a valid column address on the Multiplexed Address Bus SA[11:0]. See note 1.
SDQM[7:0]	8	$\bar{O}$ Irst(1)	<b>SDRAM DATA MASK</b> controls which of the eight bytes on the data bus should be written or read. When SDQM[7:0] asserted, the SDRAM devices do not accept/drive valid data from/to the byte lanes. When SDQM[7:0] deasserted, the SDRAM devices accept/drive valid data from/to the byte lanes. By convention, SDQM[1] masks two x8 SDRAM devices. Functionally, all SDQM[7:0] signals are equivalent.
SWE#	1	$\bar{O}$ Irst(1)	<b>SDRAM WRITE ENABLE</b> indicates that the current memory transaction is a write operation. See note 1.
SCE[1:0]#	2	$\bar{O}$ Irst(1)	<b>SDRAM CHIP ENABLE</b> enables the SDRAM devices for a memory access (1 per bank supported). See note 1.
SCKE[1:0]	2	$\bar{O}$ Irst(Q)	<b>SCKE[1:0]</b> are the clock enables for the SDRAM memory. Deasserting will place the SDRAM in self-refresh mode. See note 1.
DQ[63:0]	64	I/O Irst(1) Sync(D)	<b>DATA BUS</b> carries 64-bit data to and from memory. During a data ( $T_d$ ) cycle, read or write data is present on one or more contiguous bytes, comprising DQ[63:56], DQ[55:48], DQ[47:40], DQ[39:32], DQ[31:24], DQ[23:16], DQ[15:8] and DQ[7:0]. During write operations, unused pins are driven to determinate values.
SCB[7:0]	8	I/O Irst(1) Sync(D)	<b>ERROR CORRECTION CODE</b> carries the 8-bit ECC code to and from memory during data cycles.
ROE#	1	$\bar{O}$ Irst(1)	<b>ROM OUTPUT ENABLE</b> specifies, during a $T_A$ cycle, whether the operation is a write (1) or read (0) to the ROM interface. It remains valid during $T_D$ cycles. When ROE# is asserted, the data is transferred from the memory on RAD[16:9].
RWE#	1	$\bar{O}$ Irst(1)	<b>ROM WRITE ENABLE</b> indicates the direction data is to be transferred to/from ROM and controls the $\bar{WE}$ input on the ROM device. When RWE# is asserted, the data is transferred to the memory on DQ[7:0].
RCE[1:0]#	2	$\bar{O}$ Irst(1)	<b>FLASH CHIP ENABLE</b> enables the Flash devices for a memory access.
RALE	1	$\bar{O}$ Irst(0)	<b>ROM ADDRESS LATCH ENABLE</b> indicates the cycle in which the address on RAD[16:3] should be externally latched for the Flash subsystem.
RAD[16:9]	8	I/O 5V Irst(X) Sync(D)	<b>FLASH ADDRESS/DATA BUS:</b> During an address ( $T_a$ ) cycle, bits 16:9 contain a physical word address. During a data cycle ( $T_d$ ), bits 16:9 carry data bits 16:9 of the Flash data byte.



Table 4. Memory Controller Signals (Sheet 2 of 3)

NAME	COUNT	TYPE	DESCRIPTION
RAD[8]	1	O Prst(H)	<b>FLASH ADDRESS BUS:</b> During an address ( $T_a$ ) cycle, bit 8 contain a physical word address. <b>RAD[8]</b> , multiplexes physical address bits [22] with [8]. Refer to the MCU chapter of the <i>i960<sup>®</sup> RM/RN I/O Processor Developer's Manual</i> for details.
RAD[7]	1	O Prst(H)	<b>FLASH ADDRESS BUS:</b> During an address ( $T_a$ ) cycle, bit 7 contain a physical word address. <b>RAD[7]</b> , multiplexes physical address bits [21] with [7]. Refer to the MCU chapter of the <i>i960<sup>®</sup> RM/RN I/O Processor Developer's Manual</i> for details.
RAD[6]/ RST_MODE# (Config. Pin)	1	I/O 5V Prst(H)	<b>FLASH ADDRESS BUS:</b> During an address ( $T_a$ ) cycle, bit 6 contain a physical word address. <b>RAD[6]</b> , multiplexes physical address bits [20] with [6]. Within four clocks after the deassertion of <b>P_RST#</b> , this pin is an output only. Refer to the MCU chapter of the <i>i960<sup>®</sup> RM/RN I/O Processor Developer's Manual</i> for details. <b>RESET MODE</b> is sampled at Primary PCI bus reset to determine if the 80960RM processor is to be held in reset. If asserted, the 80960RM processor will be held in reset until the 80960 Processor Reset bit is cleared in the Extended Bridge Control Register.
RAD[5]	1	O Prst(H)	<b>FLASH ADDRESS BUS:</b> During an address ( $T_a$ ) cycle, bit 5 contain a physical word address. <b>RAD[5]</b> , multiplexes physical address bits [19] with [5]. Within four clocks after the deassertion of <b>P_RST#</b> , this pin is an output only. Refer to the MCU chapter of the <i>i960<sup>®</sup> RM/RN I/O Processor Developer's Manual</i> for details.
RAD[4]/ STEST (Config. Pin)	1	I/O 5V Prst(H)	<b>FLASH ADDRESS BUS:</b> During an address ( $T_a$ ) cycle, bit 4 contain a physical word address. <b>RAD[4]</b> , multiplexes physical address bits [18] with [4]. Within four clocks after the deassertion of <b>P_RST#</b> , this pin is an output only. Refer to the MCU chapter of the <i>i960<sup>®</sup> RM/RN I/O Processor Developer's Manual</i> for details. <b>SELF TEST</b> enables or disables the processor's internal self-test feature at initialization. <b>STEST</b> is examined at the end of <b>P_RST#</b> . When <b>STEST</b> is asserted, the processor performs its internal self-test and the external bus confidence test. When <b>STEST</b> is deasserted, the processor performs only the external bus confidence test. 0 = Self Test Disabled 1 = Self Test Enabled
RAD[3]/ RETRY (Config. Pin)	1	I/O 5V Prst(H)	<b>FLASH ADDRESS BUS:</b> During an address ( $T_a$ ) cycle, bit 3 contain a physical word address. <b>RAD[3]</b> , multiplexes physical address bits [17] with [3]. Within four clocks after the deassertion of <b>P_RST#</b> , this pin is an output only. Refer to the MCU chapter of the <i>i960<sup>®</sup> RM/RN I/O Processor Developer's Manual</i> for details. <b>RETRY</b> is sampled at Primary PCI bus reset to determine if the Primary PCI interface will be disabled. If high, the Primary PCI interface will disable PCI configuration cycles by signaling a Retry until the Configuration Cycle Retry bit is cleared in the Extended Bridge Control Register. If low, the Primary PCI interface allow configuration cycles to occur.
RAD[2]/ 32BITMEM_EN# (Config. Pin)	1	I/O 5V Prst(H)	<b>FLASH ADDRESS BUS:</b> During an address ( $T_a$ ) cycle, bit 2 contains a physical word address. Within four clocks after the deassertion of <b>P_RST#</b> , this pin is an output only. Refer to the MCU chapter of the <i>i960<sup>®</sup> RM/RN I/O Processor Developer's Manual</i> for details. <b>32-BIT MemoryEnable</b> The <b>32BITMEM_EN#</b> signal is sampled at Primary PCI Reset to notify the memory controller if 32-bit wide SDRAM memories are connected to the memory controller. If <b>32BITMEM_EN#</b> is high, the memory controller supports the 64-bit SDRAM protocol for accesses to SDRAM memories. If <b>32BITMEM_EN#</b> is low, the memory controller supports the 32-bit SDRAM protocol for accesses to SDRAM memories.

**Table 4. Memory Controller Signals (Sheet 3 of 3)**

NAME	COUNT	TYPE	DESCRIPTION
RAD[1]	1	I/O 5V Prst(H)	<b>FLASH ADDRESS BUS:</b> During an address ( $T_a$ ) cycle, bit 1 contains a physical word address. Within four clocks after the deassertion of <b>P_RST#</b> , this pin is an output only. Refer to the MCU chapter of the <i>i960<sup>®</sup> RM/RN I/O Processor Developer's Manual</i> for details.
RAD[0]	1	O Prst(H)	<b>FLASH ADDRESS BUS:</b> During an address ( $T_a$ ) cycle, bit 0 contains a physical word address. Refer to the MCU chapter of the <i>i960<sup>®</sup> RM/RN I/O Processor Developer's Manual</i> for details.

**NOTE:**

1. These pins remain functional for 20 **DCLKIN** periods after **I\_RST#** is asserted for a warm boot. The designated **Irst()** state applies after 20 **DCLKIN** periods after **I\_RST#** is asserted. For more details, refer to the MCU Chapter 8.

Table 5. Primary PCI Bus Signals (Sheet 1 of 2)

NAME	COUNT	TYPE	DESCRIPTION
P_AD[31:0]	32	I/O 5V Sync(P) Prst(Z)	<b>PRIMARY PCI ADDRESS/DATA</b> is the multiplexed primary PCI bus.
P_PAR	1	I/O 5V Sync(P) Prst(Z)	<b>PRIMARY PCI BUS PARITY</b> is even parity across P_AD[31:0] and P_C/BE[3:0]#.
P_C/BE[3:0]#	4	I/O 5V Sync(P) Prst(Z)	<b>PRIMARY PCI BUS COMMAND and BYTE ENABLES</b> are multiplexed on the same PCI pins. During the address phase, they define the bus command. During the data phase, they are used as byte enables for P_AD[31:0].
P_REQ#	1	O Prst(Z)	<b>PRIMARY PCI BUS REQUEST</b> indicates to the primary PCI bus arbiter that the 80960RM processor desires use of the PCI bus.
P_GNT#	1	I 5V Sync(P) Prst(Z)	<b>PRIMARY PCI BUS GRANT</b> indicates that access to the primary PCI bus has been granted.
P_FRAME#	1	I/O 5V Sync(P) Prst(Z)	<b>PRIMARY PCI BUS CYCLE FRAME</b> is asserted to indicate the beginning and duration of an access.
P_IRDY#	1	I/O 5V Sync(P) Prst(Z)	<b>PRIMARY PCI BUS INITIATOR READY</b> indicates the initiating agent's ability to complete the current data phase of the transaction. During a write, it indicates that valid data is present on the Address/Data bus. During a read, it indicates the processor is ready to accept the data.
P_TRDY#	1	I/O 5V Sync(P) Prst(Z)	<b>PRIMARY PCI BUS TARGET READY</b> indicates the target agent's ability to complete the current data phase of the transaction. During a read, it indicates that valid data is present on the Address/Data bus. During a write, it indicates the target is ready to accept the data.
P_STOP#	1	I/O 5V Sync(P) Prst(Z)	<b>PRIMARY PCI BUS STOP</b> indicates a request to stop the current transaction on the primary PCI bus.
P_DEVSEL#	1	I/O 5V Sync(P) Prst(Z)	<b>PRIMARY PCI BUS DEVICE SELECT</b> is driven by a target agent that has successfully decoded the address. As an input, it indicates whether or not an agent has been selected.
P_SERR#	1	I/O 5V OD Sync(P) Prst(Z)	<b>PRIMARY PCI BUS SYSTEM ERROR</b> is driven for address parity errors on the primary PCI bus.
P_CLK	1	I 5V	<b>PRIMARY PCI BUS INPUT CLOCK</b> provides the timing for all primary PCI transactions and is the clock source for all internal Huachuca units.

Table 5. Primary PCI Bus Signals (Sheet 2 of 2)

NAME	COUNT	TYPE	DESCRIPTION
P_RST#	1	I 5V Async	<b>PRIMARY RESET</b> brings PCI-specific registers, sequencers, and signals to a consistent state. When P_RST# is asserted: PCI output signals are driven to a known consistent state. PCI bus interface output signals are three-stated. open drain signals such as P_SERR# are floated. P_RST# may be asynchronous to P_CLK when asserted or deasserted. Although asynchronous, deassertion must be guaranteed to be a clean, bounce-free edge.
P_PERR#	1	I/O 5V Sync(P) Prst(Z)	<b>PRIMARY PCI BUS PARITY ERROR</b> is asserted when a data parity error occurs during a primary PCI bus transaction.
P_LOCK#	1	I 5V Sync(P)	<b>PRIMARY PCI BUS LOCK</b> indicates the need to perform an atomic operation on the primary PCI bus.
P_IDSEL	1	I 5V Sync(P)	<b>PRIMARY PCI BUS INITIALIZATION DEVICE SELECT</b> is used to select the 80960RM processor during a Configuration Read or Write command on the primary PCI bus.
P_INT[A:D]#	4	O OD Prst(Z)	<b>PRIMARY PCI BUS INTERRUPT</b> requests an interrupt. The assertion and deassertion of P_INT[A:D]# is asynchronous to P_CLK. A device asserts its P_INT[A:D]# line when requesting attention from its device driver. Once the P_INT[A:D]# signal is asserted, it remains asserted until the device driver clears the pending request. P_INT[A:D]# Interrupts are level sensitive.

Table 6. Secondary PCI Arbiter Signals

NAME	COUNT	TYPE	DESCRIPTION
S_REQ[5:0]#	6	I 5V Sync(P)	<b>SECONDARY PCI BUS REQUESTS</b> are the request signals from devices 0 through 5 on the secondary PCI bus.
S_GNT[5:0]#	6	O Srst(Z)	<b>SECONDARY PCI BUS GRANT</b> are grant signals sent to devices 5-0 on the secondary PCI bus

Table 7. Secondary PCI Bus Signals

NAME	COUNT	TYPE	DESCRIPTION
<b>S_AD[31:0]</b>	32	I/O 5V Sync(P) Srst(0)	<b>SECONDARY PCI ADDRESS/DATA</b> is the multiplexed secondary PCI bus.
<b>S_PAR</b>	1	I/O 5V Sync(P) Srst(0)	<b>SECONDARY PCI BUS PARITY</b> is even parity across <b>S_AD[31:0]</b> and <b>S_C/BE[3:0]#</b> .
<b>S_C/BE[3:0]#</b>	4	I/O 5V Sync(P) Srst(0)	<b>SECONDARY PCI BUS COMMAND</b> and <b>BYTE ENABLES</b> are multiplexed on the same PCI pins. During the address phase, they define the bus command. During the data phase, they are used as the byte enables for <b>S_AD[31:0]</b> .
<b>S_FRAME#</b>	1	I/O 5V Sync(P) Srst(Z)	<b>SECONDARY PCI BUS CYCLE FRAME</b> is asserted to indicate the beginning and duration of an access.
<b>S_IRDY#</b>	1	I/O 5V Sync(P) Srst(Z)	<b>SECONDARY PCI BUS INITIATOR READY</b> indicates the initiating agent's ability to complete the current data phase of the transaction. During a write, it indicates that valid data is present on the secondary Address/Data bus. During a read, it indicates the processor is ready to accept the data.
<b>S_TRDY#</b>	1	I/O 5V Sync(P) Srst(Z)	<b>SECONDARY PCI BUS TARGET READY</b> indicates the target agent's ability to complete the current data phase of the transaction. During a read, it indicates that valid data is present on the secondary Address/Data bus. During a write, it indicates the target is ready to accept the data.
<b>S_STOP#</b>	1	I/O 5V Sync(P) Srst(Z)	<b>SECONDARY PCI BUS STOP</b> indicates a request to stop the current transaction on the secondary PCI bus.
<b>S_DEVSEL#</b>	1	I/O 5V Sync(P) Srst(Z)	<b>SECONDARY PCI BUS DEVICE SELECT</b> is driven by a target agent that has successfully decoded the address. As an input, it indicates whether or not an agent has been selected.
<b>S_SERR#</b>	1	I/O 5V OD Sync(P) Srst(Z)	<b>SECONDARY PCI BUS SYSTEM ERROR</b> is driven for address parity errors on the secondary PCI bus.
<b>S_RST#</b>	1	O Asyn	<b>SECONDARY PCI BUS RESET</b> is an output based on <b>P_RST#</b> . It brings PCI-specific registers, sequencers, and signals to a consistent state. When <b>P_RST#</b> is asserted or <b>BCR[6]</b> is set, it causes <b>S_RST#</b> to assert and: PCI output signals are driven to a known consistent state. PCI bus interface output signals are three-stated. open drain signals such as <b>S_SERR#</b> are floated <b>S_RST#</b> may be asynchronous to <b>S_CLKIN</b> when asserted or deasserted. Although asynchronous, deassertion must be guaranteed to be a clean, bounce-free edge.
<b>S_PERR#</b>	1	I/O 5V Sync(P) Srst(Z)	<b>SECONDARY PCI BUS PARITY ERROR</b> is asserted when a data parity error during a secondary PCI bus transaction.
<b>S_LOCK#</b>	1	I/O 5V Sync(P) Srst(Z)	<b>SECONDARY PCI BUS LOCK</b> indicates the need to perform an atomic operation on the secondary PCI bus.

Table 8. JX Core Signals and Configuration Straps

NAME	COUNT	TYPE	DESCRIPTION															
XINT[3:0]#/S_INT[D:A]#	4	I 5V Async	<p><b>SECONDARY PCI BUS INTERRUPT REQUESTS.</b> S_INT[D:A]# assertion and deassertion is asynchronous to S_CLKIN. As device asserts S_INT[D:A]# when requesting attention from it device driver. When S_INT[D:A]# is asserted, it remains asserted until the device driver clears the pending request. S_INT[D:A]# interrupts are level low sensitive.</p> <p><b>EXTERNAL INTERRUPT.</b> External devices use this signal to request an interrupt service. These signals operate in dedicated mode, where each signal is assigned a dedicated interrupt level.</p> <p>The S_INT[D:A]#/XINT[3:0]# signals can be directed as follows:</p> <table border="0"> <tr> <td><b>Sec. PCI</b></td> <td><b>Primary PCI</b></td> <td>i960 core processor</td> </tr> <tr> <td>S_INTA#</td> <td>⇒</td> <td>P_INTA# or XINT0#</td> </tr> <tr> <td>S_INTB#</td> <td>⇒</td> <td>P_INTB# or XINT1#</td> </tr> <tr> <td>S_INTC#</td> <td>⇒</td> <td>P_INTC# or XINT2#</td> </tr> <tr> <td>S_INTD#</td> <td>⇒</td> <td>P_INTD# or XINT3#</td> </tr> </table>	<b>Sec. PCI</b>	<b>Primary PCI</b>	i960 core processor	S_INTA#	⇒	P_INTA# or XINT0#	S_INTB#	⇒	P_INTB# or XINT1#	S_INTC#	⇒	P_INTC# or XINT2#	S_INTD#	⇒	P_INTD# or XINT3#
<b>Sec. PCI</b>	<b>Primary PCI</b>	i960 core processor																
S_INTA#	⇒	P_INTA# or XINT0#																
S_INTB#	⇒	P_INTB# or XINT1#																
S_INTC#	⇒	P_INTC# or XINT2#																
S_INTD#	⇒	P_INTD# or XINT3#																
XINT[5:4]#	2	I 5V Async	<b>EXTERNAL INTERRUPT</b> pins are used to request 80960RM processor interrupt service.															
NMI#	1	I 5V Async	<b>NON-MASKABLE INTERRUPT</b> causes an i960 core processor non-maskable interrupt event to occur. NMI# is the highest priority interrupt source.															
VCC5REF	1	-	<b>INPUT REFERENCE VOLTAGE</b> is strapped to 5V. This reference voltage allows the 80960RM processor input pins to be 5V tolerant.															
V <sub>CCPLL</sub>	3	-	<b>PLL POWER</b> is a separate V <sub>CC</sub> supply pin for the phase lock loop clock generator. It is intended for external connection to the V <sub>CC</sub> board plane. In noisy environments, add a simple bypass filter circuit to reduce noise-induced clock jitter and its effects on timing relationships.															
FAIL#	1	O Irst(0)	<p><b>FAIL</b> indicates a failure of the processor's built-in self-test performed during initialization. FAIL# is asserted immediately upon reset and toggles during self-test to indicate the status of individual tests:</p> <p>When self-test passes, the processor deasserts FAIL# and commences operation from user code.</p> <p>When self-test fails, the processor asserts FAIL# and then stops executing. Self-test failing does not cause the bridge to stop execution.</p> <p>0 = Self Test Failed 1 = Self Test Passed</p>															

Table 9. I<sup>2</sup>C, JTAG, Core Signals

NAME	COUNT	TYPE	DESCRIPTION
TCK	1	I 5V	<b>TEST CLOCK</b> is an input which provides the clocking function for the IEEE 1149.1 Boundary Scan Testing (JTAG). State information and data are clocked into the component on the rising edge and data is clocked out of the component on the falling edge.
TDI	1	I 5V Sync(T)	<b>TEST DATA INPUT</b> is the serial input pin for the JTAG feature. TDI is sampled on the rising edge of <b>TCK</b> , during the SHIFT-IR and SHIFT-DR states of the Test Access Port. This signal has a weak internal pullup to ensure proper operation when this signal is unconnected.
TDO	1	O	<b>TEST DATA OUTPUT</b> is the serial output pin for the JTAG feature. <b>TDO</b> is driven on the falling edge of <b>TCK</b> during the SHIFT-IR and SHIFT-DR states of the Test Access Port. At other times, <b>TDO</b> floats.
TRST#	1	I 5V Asyn	<b>TEST RESET</b> asynchronously resets the Test Access Port (TAP) controller function of IEEE 1149.1 Boundary Scan Testing (JTAG). This signal has a weak internal pullup to ensure proper operation when this signal is unconnected.
TMS	1	I 5V Sync(T)	<b>TEST MODE SELECT</b> is sampled at the rising edge of <b>TCK</b> to select the operation of the test logic for IEEE 1149.1 Boundary Scan testing. This signal has a weak internal pullup to ensure proper operation when this signal is unconnected.
SDA	1	I/O 5V OD Irst(Z)	<b>I<sup>2</sup>C DATA</b> is used for data transfer and arbitration on the I <sup>2</sup> C bus.
SCL	1	I/O 5V OD Irst(Z)	<b>I<sup>2</sup>C CLOCK</b> provides synchronous operation of the I <sup>2</sup> C bus.
LCDINIT#	1	I Sync(I)	<b>LCD INITIALIZATION</b> is a static signal used to initialize the internal logic for the LCD960 debugger. This signal has an internal pullup for normal operation.
I_RST#	1	O Asyn	<b>INTERNAL BUS RESET</b> indicates when the internal bus has been reset with <b>P_RST#</b> or a software reset.
ONCE# (Config. Pin)	1	I 5V	<b>ONCE MODE</b> : The processor samples this pin during reset. If it is asserted LOW at the end of reset, the processor enters <b>ONCE</b> Mode. In 80960RM processor Mode, the processor stops all clocks and floats all output pins except the <b>TDO</b> pin. The pin has a weak internal pullup which is active during reset to ensure normal operation if the pin is left unconnected.

### 3.1.2 540-Lead H-PBGA Package

Figure 3. 540L H-PBGA Package Diagram (Top and Side View)

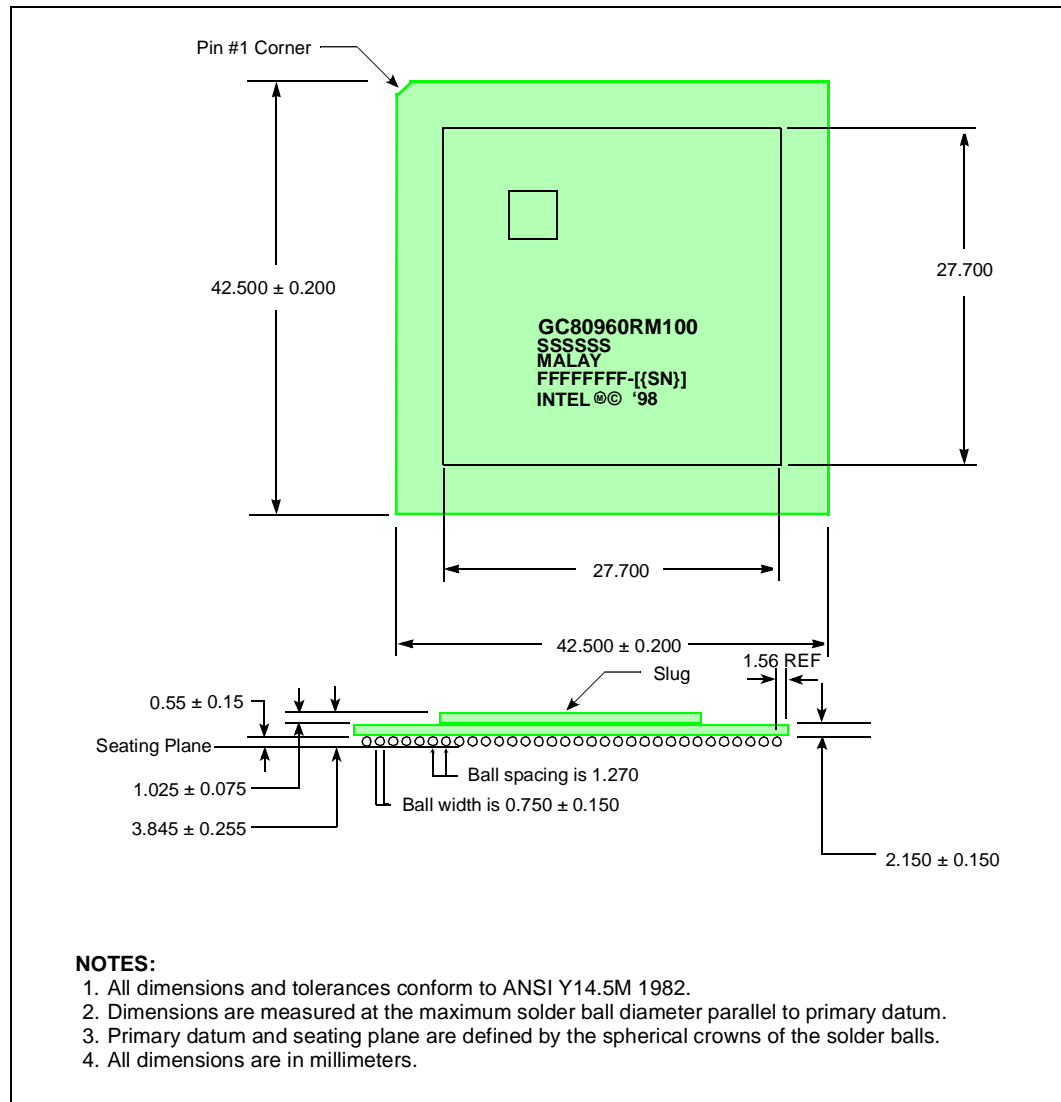



Figure 4. 540L H-PBGA Package Diagram (Bottom View)

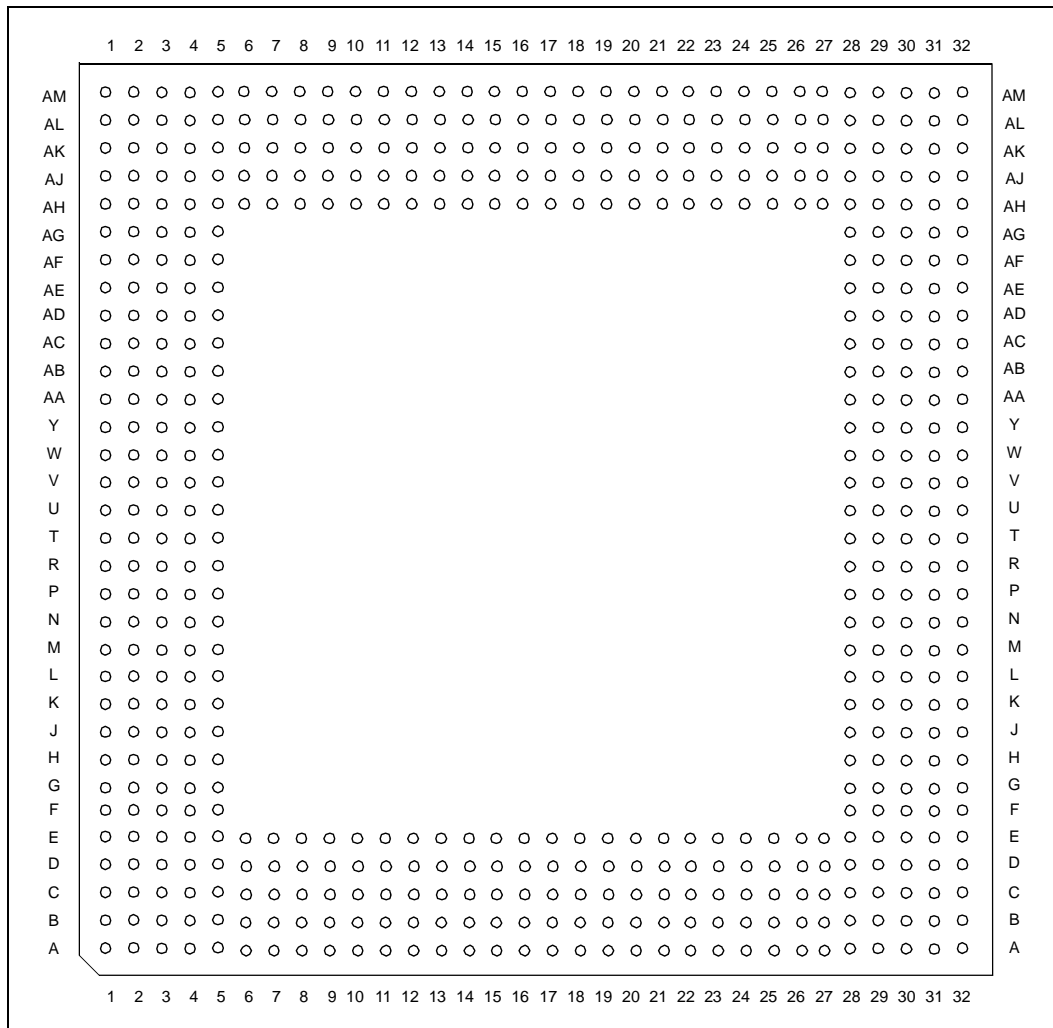

Table 10. 540-Lead H-PBGA Package — Signal Name Order (Sheet 1 of 5)

Signal	Ball #	Signal	Ball #	Signal	Ball #
DCLKIN	E21	DQ35	C24	P_AD03	T1
DCLKOUT	A22	DQ36	E24	P_AD04	T3
DQ00	D22	DQ37	B25	P_AD05	T4
DQ01	A23	DQ38	E25	P_AD06	T5
DQ02	C23	DQ39	C26	P_AD07	R1
DQ03	A24	DQ40	A27	P_AD08	R3
DQ04	D24	DQ41	C27	P_AD09	R5
DQ05	A25	DQ42	A28	P_AD10	P1
DQ06	C25	DQ43	G32	P_AD11	P3
DQ07	A26	DQ44	H31	P_AD12	P4
DQ08	E26	DQ45	H28	P_AD13	P5
DQ09	B27	DQ46	J30	P_AD14	N1
DQ10	E27	DQ47	J28	P_AD15	N2
DQ11	C28	DQ48	W28	P_AD16	K3
DQ12	H32	DQ49	Y31	P_AD17	K4
DQ13	H30	DQ50	Y28	P_AD18	K5
DQ14	J32	DQ51	AA30	P_AD19	J1
DQ15	J29	DQ52	AA28	P_AD20	J2
DQ16	W29	DQ53	AB31	P_AD21	J3
DQ17	Y32	DQ54	AB28	P_AD22	J5
DQ18	Y30	DQ55	AC30	P_AD23	H1
DQ19	AA32	DQ56	AC28	P_AD24	H5
DQ20	AA29	DQ57	AD31	P_AD25	G1
DQ21	AB32	DQ58	AD28	P_AD26	G2
DQ22	AB30	DQ59	AE30	P_AD27	G3
DQ23	AC32	DQ60	AE28	P_AD28	E5
DQ24	AC29	DQ61	AF31	P_AD29	A6
DQ25	AD32	DQ62	AF28	P_AD30	C6
DQ26	AD30	DQ63	AH32	P_AD31	D6
DQ27	AE32	FAIL#	E12	N/C	A16
DQ28	AE29	LCDINIT#	A21	N/C	G5
DQ29	AF32	I_RST#	A11	N/C	U5
DQ30	AF30	ONCE#	C21	N/C	V1
DQ31	AG32	NMI#	A9	N/C	V3
DQ32	E22	P_AD00	U1	N/C	V4
DQ33	B23	P_AD01	U2	N/C	V5
DQ34	E23	P_AD02	U3	N/C	V28

**Table 10. 540-Lead H-PBGA Package — Signal Name Order** (Sheet 2 of 5)

Signal	Ball #	Signal	Ball #	Signal	Ball #
N/C	W1	N/C	AH4	N/C	AM13
N/C	W2	N/C	AH6	P_CLK	C20
N/C	W3	N/C	AH7	P_C/BE0#	R2
N/C	W5	N/C	AH8	P_C/BE1#	N5
N/C	Y1	N/C	AH9	P_C/BE2#	K1
N/C	Y3	N/C	AH10	P_C/BE3#	H4
N/C	Y4	N/C	AH11	P_DEVSEL#	L1
N/C	Y5	N/C	AH12	P_FRAME#	L5
N/C	AA1	N/C	AH13	P_GNT#	A7
N/C	AA2	N/C	AJ2	P_IDSEL	H3
N/C	AA3	N/C	AJ5	P_INTA#	E8
N/C	AA5	N/C	AJ7	P_INTB#	D8
N/C	AB1	N/C	AJ9	P_INTC#	E7
N/C	AB3	N/C	AJ11	P_INTD#	C7
N/C	AB4	N/C	AJ13	P_IRDY#	L3
N/C	AB5	N/C	AK5	P_LOCK#	M4
N/C	AC1	N/C	AK6	P_PAR	N3
N/C	AC2	N/C	AK7	P_PERR#	M3
N/C	AC3	N/C	AK8	P_SERR#	M1
N/C	AC5	N/C	AK9	P_STOP#	M5
N/C	AD1	N/C	AK10	P_REQ#	E6
N/C	AD3	N/C	AK11	P_RST#	B7
N/C	AD4	N/C	AK12	P_TRDY#	L2
N/C	AD5	N/C	AK13	RAD00	A13
N/C	AE1	N/C	AL6	RAD01	B13
N/C	AE2	N/C	AL8	RAD02	C13
N/C	AE3	N/C	AL10	RAD03	E13
N/C	AE5	N/C	AL12	RAD04	A14
N/C	AF1	N/C	AL16	RAD05	C14
N/C	AF3	N/C	AM5	RAD06	D14
N/C	AF4	N/C	AM6	RAD07	E14
N/C	AF5	N/C	AM7	RAD08	A15
N/C	AG1	N/C	AM8	RAD09	C15
N/C	AG2	N/C	AM9	RAD10	E15
N/C	AG3	N/C	AM10	RAD11	E17
N/C	AH1	N/C	AM11	RAD12	A18
N/C	AH3	N/C	AM12	RAD13	C18

Table 10. 540-Lead H-PBGA Package — Signal Name Order (Sheet 3 of 5)

Signal	Ball #	Signal	Ball #	Signal	Ball #
RAD14	D18	SDQM0	L29	S_AD27	AH25
RAD15	E18	SDQM1	M32	S_AD28	AJ25
RAD16	A19	SDQM2	U30	S_AD29	AK25
RALE	B19	SDQM3	U28	S_AD30	AM25
RCE0#	C19	SDQM4	L28	S_AD31	AH26
RCE1#	E19	SDQM5	M31	S_C/BE0#	AH17
ROE#	D20	SDQM6	U29	S_C/BE1#	AJ19
RWE#	A20	SDQM7	V32	S_C/BE2#	AM21
SA00	N30	SRAS#	N32	S_C/BE3#	AH24
SA01	N29	SWE#	L32	S_DEVSEL#	AM20
SA02	N28	S_AD00	AH14	S_FRAME#	AK21
SA03	P32	S_AD01	AK14	S_GNT0#	AM26
SA04	P31	S_AD02	AL14	S_GNT1#	AJ27
SA05	P30	S_AD03	AM14	S_GNT2#	AM27
SA06	P28	S_AD04	AH15	S_GNT3#	AK28
SA07	R32	S_AD05	AJ15	S_GNT4#	AM28
SA08	R30	S_AD06	AK15	S_GNT5#	AK29
SA09	R29	S_AD07	AM15	S_IRDY#	AJ21
SA10	R28	S_AD08	AJ17	S_LOCK#	AK20
SA11	T32	S_AD09	AK17	S_PAR	AK19
SBA0	T31	S_AD10	AM17	S_PERR#	AH20
SBA1	T30	S_AD11	AH18	S_REQ0#	AL26
SCAS#	L30	S_AD12	AK18	S_REQ1#	AH27
SCB0	K32	S_AD13	AL18	S_REQ2#	AK27
SCB1	K30	S_AD14	AM18	S_REQ3#	AH28
SCB2	V31	S_AD15	AH19	S_REQ4#	AL28
SCB3	W32	S_AD16	AH22	S_REQ5#	AJ29
SCB4	K31	S_AD17	AK22	S_RST#	AK26
SCB5	K28	S_AD18	AL22	S_SERR#	AM19
SCB6	V30	S_AD19	AM22	S_STOP#	AL20
SCB7	W30	S_AD20	AH23	S_TRDY#	AH21
SCE0#	M30	S_AD21	AJ23	TCK	C12
SCE1#	M28	S_AD22	AK23	TDI	A12
SCKE0	T28	S_AD23	AM23	TDO	E11
SCKE1	U32	S_AD24	AK24	TMS	B11
SCL	A8	S_AD25	AL24	TRST#	C11
SDA	C8	S_AD26	AM24	V <sub>CC</sub>	A17

**Table 10. 540-Lead H-PBGA Package — Signal Name Order** (Sheet 4 of 5)

Signal	Ball #	Signal	Ball #	Signal	Ball #
V <sub>CC</sub>	A29	V <sub>CC</sub>	F2	V <sub>CC</sub>	AL3
V <sub>CC</sub>	B2	V <sub>CC</sub>	F3	V <sub>CC</sub>	AL4
V <sub>CC</sub>	B3	V <sub>CC</sub>	F4	V <sub>CC</sub>	AL5
V <sub>CC</sub>	B4	V <sub>CC</sub>	G30	V <sub>CC</sub>	AL7
V <sub>CC</sub>	B5	V <sub>CC</sub>	G31	V <sub>CC</sub>	AL9
V <sub>CC</sub>	B6	V <sub>CC</sub>	H2	V <sub>CC</sub>	AL11
V <sub>CC</sub>	B8	V <sub>CC</sub>	J31	V <sub>CC</sub>	AL13
V <sub>CC</sub>	B10	V <sub>CC</sub>	K2	V <sub>CC</sub>	AL15
V <sub>CC</sub>	B12	V <sub>CC</sub>	L31	V <sub>CC</sub>	AL17
V <sub>CC</sub>	B14	V <sub>CC</sub>	M2	V <sub>CC</sub>	AL19
V <sub>CC</sub>	B16	V <sub>CC</sub>	N31	V <sub>CC</sub>	AL21
V <sub>CC</sub>	B17	V <sub>CC</sub>	P2	V <sub>CC</sub>	AL23
V <sub>CC</sub>	B18	V <sub>CC</sub>	R31	V <sub>CC</sub>	AL25
V <sub>CC</sub>	B20	V <sub>CC</sub>	T2	V <sub>CC</sub>	AL27
V <sub>CC</sub>	B22	V <sub>CC</sub>	U31	V <sub>CC</sub>	AL29
V <sub>CC</sub>	B24	V <sub>CC</sub>	V2	V <sub>CC</sub>	AL30
V <sub>CC</sub>	B26	V <sub>CC</sub>	W31	V <sub>CC</sub>	AL31
V <sub>CC</sub>	B28	V <sub>CC</sub>	Y2	V <sub>CC</sub>	AM4
V <sub>CC</sub>	B29	V <sub>CC</sub>	AA31	V <sub>CC5REF</sub>	E20
V <sub>CC</sub>	B30	V <sub>CC</sub>	AB2	V <sub>CCPLL1</sub>	C22
V <sub>CC</sub>	B31	V <sub>CC</sub>	AC31	V <sub>CCPLL2</sub>	B15
V <sub>CC</sub>	C2	V <sub>CC</sub>	AD2	V <sub>CCPLL3</sub>	D26
V <sub>CC</sub>	C3	V <sub>CC</sub>	AE31	V <sub>SS</sub>	A1
V <sub>CC</sub>	C5	V <sub>CC</sub>	AF2	V <sub>SS</sub>	A2
V <sub>CC</sub>	C16	V <sub>CC</sub>	AG30	V <sub>SS</sub>	A3
V <sub>CC</sub>	C29	V <sub>CC</sub>	AG31	V <sub>SS</sub>	A4
V <sub>CC</sub>	C30	V <sub>CC</sub>	AH2	V <sub>SS</sub>	A5
V <sub>CC</sub>	C31	V <sub>CC</sub>	AH30	V <sub>SS</sub>	A30
V <sub>CC</sub>	D2	V <sub>CC</sub>	AH31	V <sub>SS</sub>	A31
V <sub>CC</sub>	D12	V <sub>CC</sub>	AJ1	V <sub>SS</sub>	A32
V <sub>CC</sub>	D30	V <sub>CC</sub>	AJ30	V <sub>SS</sub>	B1
V <sub>CC</sub>	D31	V <sub>CC</sub>	AJ31	V <sub>SS</sub>	B21
V <sub>CC</sub>	D32	V <sub>CC</sub>	AK2	V <sub>SS</sub>	B32
V <sub>CC</sub>	E2	V <sub>CC</sub>	AK3	V <sub>SS</sub>	C1
V <sub>CC</sub>	E3	V <sub>CC</sub>	AK30	V <sub>SS</sub>	C4
V <sub>CC</sub>	E10	V <sub>CC</sub>	AK31	V <sub>SS</sub>	C17
V <sub>CC</sub>	E31	V <sub>CC</sub>	AL2	V <sub>SS</sub>	C32

Table 10. 540-Lead H-PBGA Package — Signal Name Order (Sheet 5 of 5)

Signal	Ball #	Signal	Ball #	Signal	Ball #
V <sub>SS</sub>	D1	V <sub>SS</sub>	G4	V <sub>SS</sub>	AJ8
V <sub>SS</sub>	D3	V <sub>SS</sub>	G28	V <sub>SS</sub>	AJ10
V <sub>SS</sub>	D4	V <sub>SS</sub>	G29	V <sub>SS</sub>	AJ12
V <sub>SS</sub>	D5	V <sub>SS</sub>	H29	V <sub>SS</sub>	AJ14
V <sub>SS</sub>	D7	V <sub>SS</sub>	J4	V <sub>SS</sub>	AJ16
V <sub>SS</sub>	D9	V <sub>SS</sub>	K29	V <sub>SS</sub>	AJ18
V <sub>SS</sub>	D11	V <sub>SS</sub>	L4	V <sub>SS</sub>	AJ20
V <sub>SS</sub>	D13	V <sub>SS</sub>	M29	V <sub>SS</sub>	AJ22
V <sub>SS</sub>	D15	V <sub>SS</sub>	N4	V <sub>SS</sub>	AJ24
V <sub>SS</sub>	D16	V <sub>SS</sub>	P29	V <sub>SS</sub>	AJ26
V <sub>SS</sub>	D17	V <sub>SS</sub>	R4	V <sub>SS</sub>	AJ28
V <sub>SS</sub>	D19	V <sub>SS</sub>	T29	V <sub>SS</sub>	AJ32
V <sub>SS</sub>	D21	V <sub>SS</sub>	U4	V <sub>SS</sub>	AK1
V <sub>SS</sub>	D23	V <sub>SS</sub>	V29	V <sub>SS</sub>	AK4
V <sub>SS</sub>	D25	V <sub>SS</sub>	W4	V <sub>SS</sub>	AK16
V <sub>SS</sub>	D27	V <sub>SS</sub>	Y29	V <sub>SS</sub>	AK32
V <sub>SS</sub>	D28	V <sub>SS</sub>	AA4	V <sub>SS</sub>	AL1
V <sub>SS</sub>	D29	V <sub>SS</sub>	AB29	V <sub>SS</sub>	AL32
V <sub>SS</sub>	E1	V <sub>SS</sub>	AC4	V <sub>SS</sub>	AM1
V <sub>SS</sub>	E4	V <sub>SS</sub>	AD29	V <sub>SS</sub>	AM2
V <sub>SS</sub>	E16	V <sub>SS</sub>	AE4	V <sub>SS</sub>	AM3
V <sub>SS</sub>	E28	V <sub>SS</sub>	AF29	V <sub>CC</sub>	AM16
V <sub>SS</sub>	E29	V <sub>SS</sub>	AG4	V <sub>SS</sub>	AM29
V <sub>SS</sub>	E30	V <sub>SS</sub>	AG5	V <sub>SS</sub>	AM30
V <sub>SS</sub>	E32	V <sub>SS</sub>	AG28	V <sub>SS</sub>	AM31
V <sub>SS</sub>	F1	V <sub>SS</sub>	AG29	V <sub>SS</sub>	AM32
V <sub>SS</sub>	F5	V <sub>SS</sub>	AH5	XINT0#	B9
V <sub>SS</sub>	F28	V <sub>SS</sub>	AH16	XINT1#	C9
V <sub>SS</sub>	F29	V <sub>SS</sub>	AH29	XINT2#	E9
V <sub>SS</sub>	F30	V <sub>SS</sub>	AJ3	XINT3#	A10
V <sub>SS</sub>	F31	V <sub>SS</sub>	AJ4	XINT4#	C10
V <sub>SS</sub>	F32	V <sub>SS</sub>	AJ6	XINT5#	D10

Table 11. 540-Lead H-PBGA Pinout — Ballpad Number Order (Sheet 1 of 5)

Ball #	Signal	Ball #	Signal	Ball #	Signal
A1	V <sub>SS</sub>	B6	V <sub>CC</sub>	C11	TRST#
A2	V <sub>SS</sub>	B7	P_RST#	C12	TCK
A3	V <sub>SS</sub>	B8	V <sub>CC</sub>	C13	RAD02
A4	V <sub>SS</sub>	B9	XINT0#	C14	RAD05
A5	V <sub>SS</sub>	B10	V <sub>CC</sub>	C15	RAD09
A6	P_AD29	B11	TMS	C16	V <sub>CC</sub>
A7	P_GNT#	B12	V <sub>CC</sub>	C17	V <sub>SS</sub>
A8	SCL	B13	RAD01	C18	RAD13
A9	NMI#	B14	V <sub>CC</sub>	C19	RCE0#
A10	XINT3#	B15	V <sub>CCPLL2</sub>	C20	P_CLK
A11	I_RST#	B16	V <sub>CC</sub>	C21	ONCE#
A12	TDI	B17	V <sub>CC</sub>	C22	V <sub>CCPLL1</sub>
A13	RAD00	B18	V <sub>CC</sub>	C23	DQ02
A14	RAD04	B19	RALE	C24	DQ35
A15	RAD08	B20	V <sub>CC</sub>	C25	DQ06
A16	N/C	B21	V <sub>SS</sub>	C26	DQ39
A17	V <sub>CC</sub>	B22	V <sub>CC</sub>	C27	DQ41
A18	RAD12	B23	DQ33	C28	DQ11
A19	RAD16	B24	V <sub>CC</sub>	C29	V <sub>CC</sub>
A20	RWE#	B25	DQ37	C30	V <sub>CC</sub>
A21	LCDINIT#	B26	V <sub>CC</sub>	C31	V <sub>CC</sub>
A22	DCLKOUT	B27	DQ09	C32	V <sub>SS</sub>
A23	DQ01	B28	V <sub>CC</sub>	D1	V <sub>SS</sub>
A24	DQ03	B29	V <sub>CC</sub>	D2	V <sub>CC</sub>
A25	DQ05	B30	V <sub>CC</sub>	D3	V <sub>SS</sub>
A26	DQ07	B31	V <sub>CC</sub>	D4	V <sub>SS</sub>
A27	DQ40	B32	V <sub>SS</sub>	D5	V <sub>SS</sub>
A28	DQ42	C1	V <sub>SS</sub>	D6	P_AD31
A29	V <sub>CC</sub>	C2	V <sub>CC</sub>	D7	V <sub>SS</sub>
A30	V <sub>SS</sub>	C3	V <sub>CC</sub>	D8	P_INTB#
A31	V <sub>SS</sub>	C4	V <sub>SS</sub>	D9	V <sub>SS</sub>
A32	V <sub>SS</sub>	C5	V <sub>CC</sub>	D10	XINT5#
B1	V <sub>SS</sub>	C6	P_AD30	D11	V <sub>SS</sub>
B2	V <sub>CC</sub>	C7	P_INTD#	D12	V <sub>CC</sub>
B3	V <sub>CC</sub>	C8	SDA	D13	V <sub>SS</sub>
B4	V <sub>CC</sub>	C9	XINT1#	D14	RAD06
B5	V <sub>CC</sub>	C10	XINT4#	D15	V <sub>SS</sub>

Table 11. 540-Lead H-PBGA Pinout — Ballpad Number Order (Sheet 2 of 5)

Ball #	Signal	Ball #	Signal	Ball #	Signal
D16	V <sub>SS</sub>	E21	DCLKIN	H28	DQ45
D17	V <sub>SS</sub>	E22	DQ32	H29	V <sub>SS</sub>
D18	RAD14	E23	DQ34	H30	DQ13
D19	V <sub>SS</sub>	E24	DQ36	H31	DQ44
D20	ROE#	E25	DQ38	H32	DQ12
D21	V <sub>SS</sub>	E26	DQ08	J1	P_AD19
D22	DQ00	E27	DQ10	J2	P_AD20
D23	V <sub>SS</sub>	E28	V <sub>SS</sub>	J3	P_AD21
D24	DQ04	E29	V <sub>SS</sub>	J4	V <sub>SS</sub>
D25	V <sub>SS</sub>	E30	V <sub>SS</sub>	J5	P_AD22
D26	V <sub>CC</sub> PLL3	E31	V <sub>CC</sub>	J28	DQ47
D27	V <sub>SS</sub>	E32	V <sub>SS</sub>	J29	DQ15
D28	V <sub>SS</sub>	F1	V <sub>SS</sub>	J30	DQ46
D29	V <sub>SS</sub>	F2	V <sub>CC</sub>	J31	V <sub>CC</sub>
D30	V <sub>CC</sub>	F3	V <sub>CC</sub>	J32	DQ14
D31	V <sub>CC</sub>	F4	V <sub>CC</sub>	K1	P_C/BE2#
D32	V <sub>CC</sub>	F5	V <sub>SS</sub>	K2	V <sub>CC</sub>
E1	V <sub>SS</sub>	F28	V <sub>SS</sub>	K3	P_AD16
E2	V <sub>CC</sub>	F29	V <sub>SS</sub>	K4	P_AD17
E3	V <sub>CC</sub>	F30	V <sub>SS</sub>	K5	P_AD18
E4	V <sub>SS</sub>	F31	V <sub>SS</sub>	K28	SCB5
E5	P_AD28	F32	V <sub>SS</sub>	K29	V <sub>SS</sub>
E6	P_REQ#	G1	P_AD25	K30	SCB1
E7	P_INTC#	G2	P_AD26	K31	SCB4
E8	P_INTA#	G3	P_AD27	K32	SCB0
E9	XINT2#	G4	V <sub>SS</sub>	L1	P_DEVSEL#
E10	V <sub>CC</sub>	G5	N/C	L2	P_TRDY#
E11	TDO	G28	V <sub>SS</sub>	L3	P_IRDY#
E12	FAIL#	G29	V <sub>SS</sub>	L4	V <sub>SS</sub>
E13	RAD03	G30	V <sub>CC</sub>	L5	P_FRAME#
E14	RAD07	G31	V <sub>CC</sub>	L28	SDQM4
E15	RAD10	G32	DQ43	L29	SDQM0
E16	V <sub>SS</sub>	H1	P_AD23	L30	SCAS#
E17	RAD11	H2	V <sub>CC</sub>	L31	V <sub>CC</sub>
E18	RAD15	H3	P_IDSEL	L32	SWE#
E19	RCE1#	H4	P_C/BE3#	M1	P_SERR#
E20	V <sub>CC</sub> 5REF	H5	P_AD24	M2	V <sub>CC</sub>



Table 11. 540-Lead H-PBGA Pinout — Ballpad Number Order (Sheet 3 of 5)

Ball #	Signal	Ball #	Signal	Ball #	Signal
M3	P_PERR#	R32	SA07	W29	DQ16
M4	P_LOCK#	T1	P_AD03	W30	SCB7
M5	P_STOP#	T2	V <sub>CC</sub>	W31	V <sub>CC</sub>
M28	SCE1#	T3	P_AD04	W32	SCB3
M29	V <sub>SS</sub>	T4	P_AD05	Y1	N/C
M30	SCE0#	T5	P_AD06	Y2	V <sub>CC</sub>
M31	SDQM5	T28	SCKE0	Y3	N/C
M32	SDQM1	T29	V <sub>SS</sub>	Y4	N/C
N1	P_AD14	T30	SBA1	Y5	N/C
N2	P_AD15	T31	SBA0	Y28	DQ50
N3	P_PAR	T32	SA11	Y29	V <sub>SS</sub>
N4	V <sub>SS</sub>	U1	P_AD00	Y30	DQ18
N5	P_C/BE1#	U2	P_AD01	Y31	DQ49
N28	SA02	U3	P_AD02	Y32	DQ17
N29	SA01	U4	V <sub>SS</sub>	AA1	N/C
N30	SA00	U5	N/C	AA2	N/C
N31	V <sub>CC</sub>	U28	SDQM3	AA3	N/C
N32	SRAS#	U29	SDQM6	AA4	V <sub>SS</sub>
P1	P_AD10	U30	SDQM2	AA5	N/C
P2	V <sub>CC</sub>	U31	V <sub>CC</sub>	AA28	DQ52
P3	P_AD11	U32	SCKE1	AA29	DQ20
P4	P_AD12	V1	N/C	AA30	DQ51
P5	P_AD13	V2	V <sub>CC</sub>	AA31	V <sub>CC</sub>
P28	SA06	V3	N/C	AA32	DQ19
P29	V <sub>SS</sub>	V4	N/C	AB1	N/C
P30	SA05	V5	N/C	AB2	V <sub>CC</sub>
P31	SA04	V28	N/C	AB3	N/C
P32	SA03	V29	V <sub>SS</sub>	AB4	N/C
R1	P_AD07	V30	SCB6	AB5	N/C
R2	P_C/BE0#	V31	SCB2	AB28	DQ54
R3	P_AD08	V32	SDQM7	AB29	V <sub>SS</sub>
R4	V <sub>SS</sub>	W1	N/C	AB30	DQ22
R5	P_AD09	W2	N/C	AB31	DQ53
R28	SA10	W3	N/C	AB32	DQ21
R29	SA09	W4	V <sub>SS</sub>	AC1	N/C
R30	SA08	W5	N/C	AC2	N/C
R31	V <sub>CC</sub>	W28	DQ48	AC3	N/C

Table 11. 540-Lead H-PBGA Pinout — Ballpad Number Order (Sheet 4 of 5)

Ball #	Signal	Ball #	Signal	Ball #	Signal
AC4	V <sub>SS</sub>	AG1	N/C	AH28	S_REQ3#
AC5	N/C	AG2	N/C	AH29	V <sub>SS</sub>
AC28	DQ56	AG3	N/C	AH30	V <sub>CC</sub>
AC29	DQ24	AG4	V <sub>SS</sub>	AH31	V <sub>CC</sub>
AC30	DQ55	AG5	V <sub>SS</sub>	AH32	DQ63
AC31	V <sub>CC</sub>	AG28	V <sub>SS</sub>	AJ1	V <sub>CC</sub>
AC32	DQ23	AG29	V <sub>SS</sub>	AJ2	N/C
AD1	N/C	AG30	V <sub>CC</sub>	AJ3	V <sub>SS</sub>
AD2	V <sub>CC</sub>	AG31	V <sub>CC</sub>	AJ4	V <sub>SS</sub>
AD3	N/C	AG32	DQ31	AJ5	N/C
AD4	N/C	AH1	N/C	AJ6	V <sub>SS</sub>
AD5	N/C	AH2	V <sub>CC</sub>	AJ7	N/C
AD28	DQ58	AH3	N/C	AJ8	V <sub>SS</sub>
AD29	V <sub>SS</sub>	AH4	N/C	AJ9	N/C
AD30	DQ26	AH5	V <sub>SS</sub>	AJ10	V <sub>SS</sub>
AD31	DQ57	AH6	N/C	AJ11	N/C
AD32	DQ25	AH7	N/C	AJ12	V <sub>SS</sub>
AE1	N/C	AH8	N/C	AJ13	N/C
AE2	N/C	AH9	N/C	AJ14	V <sub>SS</sub>
AE3	N/C	AH10	N/C	AJ15	S_AD05
AE4	V <sub>SS</sub>	AH11	N/C	AJ16	V <sub>SS</sub>
AE5	N/C	AH12	N/C	AJ17	S_AD08
AE28	DQ60	AH13	N/C	AJ18	V <sub>SS</sub>
AE29	DQ28	AH14	S_AD00	AJ19	S_C/BE1#
AE30	DQ59	AH15	S_AD04	AJ20	V <sub>SS</sub>
AE31	V <sub>CC</sub>	AH16	V <sub>SS</sub>	AJ21	S_IRDY#
AE32	DQ27	AH17	S_C/BE0#	AJ22	V <sub>SS</sub>
AF1	N/C	AH18	S_AD11	AJ23	S_AD21
AF2	V <sub>CC</sub>	AH19	S_AD15	AJ24	V <sub>SS</sub>
AF3	N/C	AH20	S_PERR#	AJ25	S_AD28
AF4	N/C	AH21	S_TRDY#	AJ26	V <sub>SS</sub>
AF5	N/C	AH22	S_AD16	AJ27	S_GNT1#
AF28	DQ62	AH23	S_AD20	AJ28	V <sub>SS</sub>
AF29	V <sub>SS</sub>	AH24	S_C/BE3#	AJ29	S_REQ5#
AF30	DQ30	AH25	S_AD27	AJ30	V <sub>CC</sub>
AF31	DQ61	AH26	S_AD31	AJ31	V <sub>CC</sub>
AF32	DQ29	AH27	S_REQ1#	AJ32	V <sub>SS</sub>

Table 11. 540-Lead H-PBGA Pinout — Ballpad Number Order (Sheet 5 of 5)

Ball #	Signal	Ball #	Signal	Ball #	Signal
AK1	V <sub>SS</sub>	AL1	V <sub>SS</sub>	AM1	V <sub>SS</sub>
AK2	V <sub>CC</sub>	AL2	V <sub>CC</sub>	AM2	V <sub>SS</sub>
AK3	V <sub>CC</sub>	AL3	V <sub>CC</sub>	AM3	V <sub>SS</sub>
AK4	V <sub>SS</sub>	AL4	V <sub>CC</sub>	AM4	V <sub>CC</sub>
AK5	N/C	AL5	V <sub>CC</sub>	AM5	N/C
AK6	N/C	AL6	N/C	AM6	N/C
AK7	N/C	AL7	V <sub>CC</sub>	AM7	N/C
AK8	N/C	AL8	N/C	AM8	N/C
AK9	N/C	AL9	V <sub>CC</sub>	AM9	N/C
AK10	N/C	AL10	N/C	AM10	N/C
AK11	N/C	AL11	V <sub>CC</sub>	AM11	N/C
AK12	N/C	AL12	N/C	AM12	N/C
AK13	N/C	AL13	V <sub>CC</sub>	AM13	N/C
AK14	S_AD01	AL14	S_AD02	AM14	S_AD03
AK15	S_AD06	AL15	V <sub>CC</sub>	AM15	S_AD07
AK16	V <sub>SS</sub>	AL16	N/C	AM16	V <sub>CC</sub>
AK17	S_AD09	AL17	V <sub>CC</sub>	AM17	S_AD10
AK18	S_AD12	AL18	S_AD13	AM18	S_AD14
AK19	S_PAR	AL19	V <sub>CC</sub>	AM19	S_SERR#
AK20	S_LOCK#	AL20	S_STOP#	AM20	S_DEVSEL#
AK21	S_FRAME#	AL21	V <sub>CC</sub>	AM21	S_C/BE2#
AK22	S_AD17	AL22	S_AD18	AM22	S_AD19
AK23	S_AD22	AL23	V <sub>CC</sub>	AM23	S_AD23
AK24	S_AD24	AL24	S_AD25	AM24	S_AD26
AK25	S_AD29	AL25	V <sub>CC</sub>	AM25	S_AD30
AK26	S_RST#	AL26	S_REQ0#	AM26	S_GNT0#
AK27	S_REQ2#	AL27	V <sub>CC</sub>	AM27	S_GNT2#
AK28	S_GNT3#	AL28	S_REQ4#	AM28	S_GNT4#
AK29	S_GNT5#	AL29	V <sub>CC</sub>	AM29	V <sub>SS</sub>
AK30	V <sub>CC</sub>	AL30	V <sub>CC</sub>	AM30	V <sub>SS</sub>
AK31	V <sub>CC</sub>	AL31	V <sub>CC</sub>	AM31	V <sub>SS</sub>
AK32	V <sub>SS</sub>	AL32	V <sub>SS</sub>	AM32	V <sub>SS</sub>

## 3.2 Package Thermal Specifications

The device is specified for operation when  $T_C$  (case temperature) is within the range of 0°C to 90°C. Case temperature may be measured in any environment to determine whether the processor is within specified operating range. Measure the case temperature at the center of the top surface, opposite the ballpad.

### 3.2.1 Thermal Specifications

This section defines the terms used for thermal analysis.

#### 3.2.1.1 Ambient Temperature

Ambient temperature,  $T_A$ , is the temperature of the ambient air surrounding the package. In a system environment, ambient temperature is the temperature of the air upstream from the package.

#### 3.2.1.2 Case Temperature

To ensure functionality and reliability, the device is specified for proper operation when the case temperature,  $T_C$ , is within the specified range as indicated in [Table 12 “540-Lead H-PBGA Package Thermal Characteristics”](#) on page 32.

When measuring case temperature, attention to detail is required to ensure accuracy. If a thermocouple is used, calibrate it before taking measurements. Errors may result when the measured surface temperature is affected by the surrounding ambient air temperature. Such errors may be due to a poor thermal contact between thermocouple junction and the surface, heat loss by radiation, or conduction through thermocouple leads.

To minimize measurement errors:

- Use a 35 gauge K-type thermocouple or equivalent.
- Attach the thermocouple bead or junction to the package top surface at a location corresponding to the center of the die ([Figure 5A](#)). The center of the die gives a more accurate measurement and less variation as the boundary condition changes.
- Attach the thermocouple bead at a 0° angle with respect to the package as shown in [Figure 5A](#), when no heatsink is attached.
- When a passive heat sink is attached, a groove is made on the bottom surface of the heatsink and the thermocouple is attached at a 0° angle, as shown in [Figure 5B](#).

**Figure 5. Thermocouple Attachment - A) No Heatsink / B) With Heatsink**

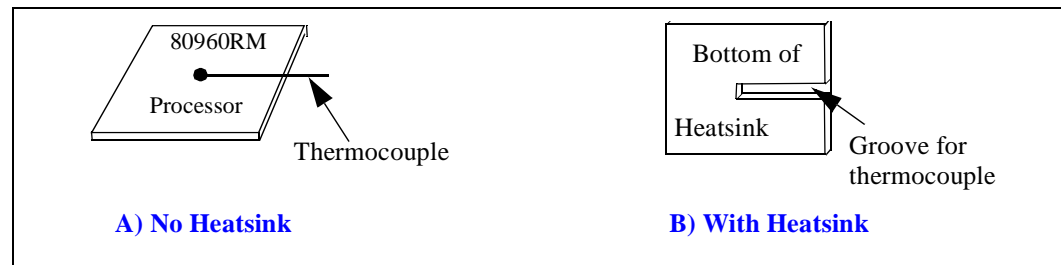

### 3.2.1.3 Thermal Resistance

The thermal resistance value for the case-to-ambient,  $\theta_{CA}$ , is used as a measure of the cooling solution's thermal performance.

## 3.2.2 Thermal Analysis

Table 12 lists the case-to-ambient thermal resistances of the 80960RM for different air flow rates with and without a heat sink.

To calculate  $T_A$ , the maximum ambient temperature to conform to a particular case temperature:

$$T_A = T_C - P (\theta_{CA})$$

Compute P by multiplying  $I_{CC}$  and  $V_{CC}$ . Values for  $\theta_{JC}$  and  $\theta_{CA}$  are given in Table 12.

Junction temperature ( $T_J$ ) is commonly used in reliability calculations.  $T_J$  can be calculated from  $\theta_{JC}$  (thermal resistance from junction to case) using the following equation:

$$T_J = T_C + P (\theta_{JC})$$

Similarly, when  $T_A$  is known, the corresponding case temperature ( $T_C$ ) can be calculated as follows:

$$T_C = T_A + P (\theta_{CA})$$

The  $\theta_{JA}$  (Junction to Ambient) for this package is currently estimated at 4.77° C/Watt with no airflow and no heatsink. The  $\theta_{JA}$  (Junction to Ambient) for this package is currently estimated at 4.18° C/Watt with no airflow and a passive heatsink:

$$\theta_{JA} = \theta_{JC} + \theta_{CA}$$

**Table 12. 540-Lead H-PBGA Package Thermal Characteristics**

Thermal Resistance — °C/Watt								
Parameter	Airflow — ft./min (m/sec)							
	0 (0)	50 (0.25)	100 (0.50)	200 (1.01)	300 (1.52)	400 (2.03)	600 (3.04)	800 (4.06)
$\theta_{JC}$ (Junction-to-Case)	0.3	0.3	0.3	0.3	0.3	0.3	0.3	0.3
$\theta_{CA}$ (Case-to-Ambient) Without Heatsink	4.47	4.14	3.94	3.69	3.51	3.36	3.13	2.95
$\theta_{CA}$ (Case-to-Ambient) With Passive Heatsink <sup>2</sup>	3.88	3.26	2.91	2.55	2.28	2.05	1.72	1.5

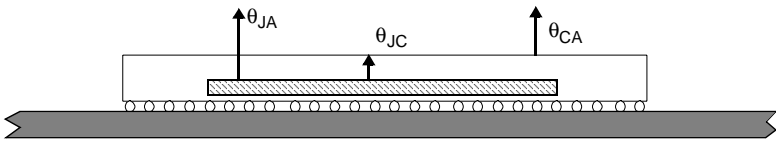

**NOTES:**

1. This table applies to a H-PBGA device soldered directly onto a board.
2. See Table 13 for heatsink information.

### 3.3 Heat Sink Information

Table 13 provides a list of suggested sources for heat sinks. This is neither an endorsement nor a warranty of the performance of any of the listed products and/or companies.

**Table 13. Heat Sink Vendors and Contacts**

Company	Factory Rep	Phone #	Fax #	Heatsink Part #
				Passive
SMI-ED (Sumitomo) 4645 S. Lakeshore Drive, #11 Tempe, AZ 85282 Email: smzjay@attmail.com	Jay Balducci	(602) 820-9889	(602) 820-9892	CX3026-001 (uses pins)
THERMALLOY, INC 2021 W. Valley View Lane Dallas Texas 75234-8993 Email:sales@thermalloyusa.com Outside of USA, refer to web page for contact information: <a href="http://www.thermalloy.com">http://www.thermalloy.com</a>	Attn: Sales	(972) 243-4321	(972) 241-4656	21933 w/o thermal grease (uses pins)  21935 with Easy Ply (thermal grease (uses pins)
AAVID (USA) One Kool Path, P.O. Box 400 Laconia, New Hampshire 03247 Web site: <a href="http://www.aavid.com">www.aavid.com</a> For offices in Asia, Europe, Middle East, Canada, or North America, see: <a href="http://www.aavid.com/">http://www.aavid.com/</a>	Attn: Sales Dept	(603) 528-3400	(603) 528-1478	NP970482 (uses pins)

### 3.4 Vendor Information

Table 14 through Table 18 provide vendor details for socket-headers, burn-in sockets, shipping trays, logic analyzer interposers and JTAG emulators for the 80960RM. This is neither an endorsement nor a warranty of the performance of any of the listed products and/or companies.

#### 3.4.1 Socket-Header Vendor

Table 14. Socket-Header Vendor

Company	Factory Representative	Phone/Fax #	Part # BGA 540-Pin
Adapter Technologies, Inc. 214-218 South 4th St. Perkasie, PA 18944	John Miller	215-258-5750/ 215-258-5760	Header: BGAH-540-0-01-3201-0277-1 Socket Carrier: BGA-540-0-02-3201-0275P-130

#### 3.4.2 Burn-in Socket Vendor

Table 15. Burn-in Socket Vendor

Company	Factory Representative	Phone #	Burn-in Socket Part #
Texas Instruments 111 Forbes Blvd. Mansfield, MA 02048	W. Ray Johnson	508-236-5375	ULGA540-005

#### 3.4.3 Shipping Tray Vendor

Table 16. Shipping Tray Vendor

Company	Factory Rep	Phone #	Shipping Tray Part #
3M	Ron Goth	602-465-5381	7-0000-21001-184-167

#### 3.4.4 Logic Analyzer Interposer Vendor

Table 17. Logic Analyzer Interposer Vendor

Company	Factory Rep	Phone/Fax #	Part #
Packard-Hughes Interconnect 17150 Von Karman Ave Irvine, CA 92614-0968	Sue Wood	714-660-5766/ 714-660-5825	1126898

#### 3.4.5 JTAG Emulator Vendor

Table 18. JTAG Emulator Vendor

Company	Factory Rep	Phone/Fax #	Part #
Corelis	Mike Winters	562-926-6727/ 562-484-6196	TBD

## 4.0 Electrical Specifications

### 4.1 Absolute Maximum Ratings

Parameter	Maximum Rating	
Storage Temperature	-55° C to + 125° C	<b>NOTICE:</b> This data sheet contains information on products in the design phase of development. Do not finalize a design with this information. Revised information will be published when the product becomes available. The specifications are subject to change without notice. Contact your local Intel representative before finalizing a design.  <b>WARNING:</b> <i>Stressing the device beyond the "Absolute Maximum Ratings" may cause permanent damage. These are stress ratings only. Operation beyond the "Operating Conditions" is not recommended and extended exposure beyond the "Operating Conditions" may affect device reliability.</i>
Case Temperature Under Bias	0° C to + 90° C	
Supply Voltage wrt. $V_{SS}$	-0.5 V to + 4.6 V	
Supply Voltage wrt. $V_{SS}$ on $V_{CC5}$	-0.5 V to + 6.5 V	
Voltage on Any Ball wrt. $V_{SS}$	-0.5 V to $V_{CC} + 0.5$ V	

Table 19. Operating Conditions

Symbol	Parameter	Min	Max	Units	Notes
$V_{CC}$	Supply Voltage	3.0	3.6	V	
$V_{CC5}$	Input Protection Bias	$V_{CC}$	$V_{CC}+2.5$	V	
$F_{P\_CLK}$	Input Clock Frequency	16	33.33	MHz	
$T_C$	Case Temperature Under Bias GC (540L PBGA)	0	90	°C	



## 4.2 VCC5REF Pin Requirements ( $V_{DIFF}$ )

In mixed voltage systems that drive 80960RM processor inputs in excess of 3.3 V, the **VCC5REF** pin must be connected to the system's 5 V supply. To limit current flow into the **VCC5REF** pin, there is a limit to the voltage differential between the **VCC5REF** pin and the other  $V_{CC}$  pins. The voltage differential between the **VCC5REF** pin and its 3.3 V  $V_{CC}$  pins should never exceed 2.25 V. This limit applies to power-up, power-down, and steady-state operation. Table 20 outlines this requirement.

If the voltage difference requirements cannot be met due to system design limitations, an alternate solution may be employed. As shown in Figure 6, a minimum of 100  $\Omega$  series resistor may be used to limit the current into the **VCC5REF** pin. This resistor ensures that current drawn by the **VCC5REF** pin does not exceed the maximum rating for this pin.

Figure 6. VCC5REF Current-Limiting Resistor

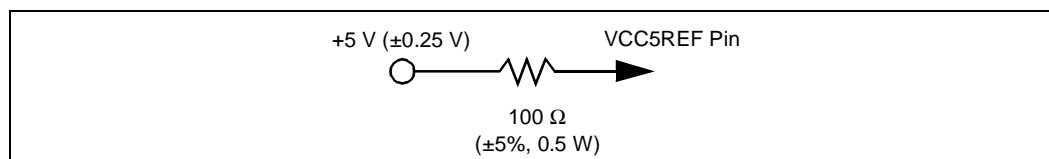

This resistor is not necessary in systems that can guarantee the  $V_{DIFF}$  specification.

In 3.3 V-only systems and systems that drive pins from 3.3 V logic, connect the **VCC5REF** pin directly to the 3.3 V  $V_{CC}$  plane.

Table 20.  $V_{DIFF}$  Specification for Dual Power Supply Requirements (3.3 V, 5 V)

Symbol	Parameter	Min	Max	Units	Notes
$V_{DIFF}$	$V_{CC5} - V_{CC}$ Difference		2.25	V	<b>VCC5REF</b> input should not exceed $V_{CC}$ by more than 2.25 V during power-up and power-down, or during steady-state operation.

## 4.3 VCCPLL Pin Requirements

To reduce clock skew on the i960 Jx processor, the  $V_{CCPLL}$  pin for the Phase Lock Loop (PLL) circuit is isolated on the pinout. The lowpass filter, as shown in Figure 7, reduces noise induced clock jitter and its effects on timing relationships in system designs. The 4.7  $\mu$ F capacitor must be (low ESR solid tantalum), the 0.01  $\mu$ F capacitor must be of the type X7R and the node connecting  $V_{CCPLL}$  must be as short as possible.

Figure 7. VCCPLL Lowpass Filter

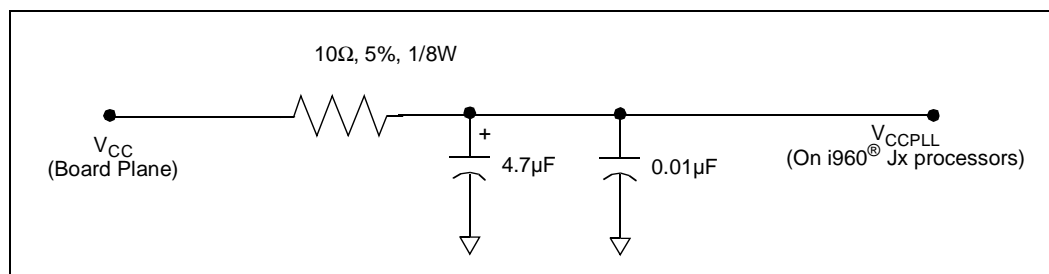

## 4.4 Targeted DC Specifications

Table 21. DC Characteristics

Symbol	Parameter	Min	Max	Units	Notes
V <sub>IL</sub>	Input Low Voltage	-0.5	0.8V	V	(1,4)
V <sub>IH</sub>	Input High Voltage	2 V	V <sub>CC</sub> + 0.5	V	(1,4)
V <sub>OL1</sub>	Output Low Voltage Processor signals		0.4	V	I <sub>OL</sub> = 6 mA (3)
V <sub>OH1</sub>	Output High Voltage Processor signals	2.4 V <sub>CC</sub> - 0.5		V	I <sub>OH</sub> = -2 mA (3) I <sub>OH</sub> = -200 μA (3)
V <sub>OL2</sub>	Output Low Voltage PCI / Flash signals		0.4	V	I <sub>OL</sub> = 6 mA (1)
V <sub>OH2</sub>	Output High Voltage PCI / Flash signals	2.4		V	I <sub>OH</sub> = -2 mA (1)
V <sub>OL3</sub>	Output Low Voltage SDRAM signals	-2.0	0.4	V	I <sub>OL</sub> = 3 mA (4)
V <sub>OH3</sub>	Output High Voltage SDRAM signals	2.4	V <sub>CC</sub> + 2.0	V	I <sub>OH</sub> = -2 mA (4)
C <sub>IN</sub>	Input Capacitance - PBGA		10	pF	F <sub>S_CLK</sub> = T <sub>F</sub> Min (1, 2)
C <sub>OUT</sub>	I/O or Output Capacitance - PBGA		10	pF	F <sub>S_CLK</sub> = T <sub>F</sub> Min (1, 2)
C <sub>CLK</sub>	S_CLK Capacitance - PBGA	5	10	pF	F <sub>S_CLK</sub> = T <sub>F</sub> Min (1, 2)
C <sub>IDSEL</sub>	IDSEL Ball Capacitance		8	pF	(1,2)
L <sub>PIN</sub>	Ball Inductance		25	nH	(1,2)

**NOTES:**

- As required by the *PCI Local Bus Specification*, Revision 2.1.
- Not tested.
- Processor signals include **RALE**, **RCE[1:0]#**, **ROE#**, **RWE#**, **XINT[5:4]#**, **NMI#**, **FAIL#**, **TDI**, **TDO**, **TMS**, **TRST#**, **SDA**, and **SCL**.
- SDRAM signals include **SA[11:0]**, **SBA[1:0]**, **SCAS#**, **SCE[1:0]#**, **SCKE[1:0]**, **SDQM[7:0]**, **SRAS#**, **SWE#**, **DCLKIN**, **DCLKOUT**, **DQ[63:0]**, and **SCB[7:0]**.

Table 22. I<sub>CC</sub> Characteristics

Symbol	Parameter	Typ	Max	Units	Notes
I <sub>LI1</sub>	Input Leakage Current for each signal except <b>TMS</b> , <b>TRST#</b> , <b>TDI</b> , <b>ONCE#</b> , <b>RAD[8:0]</b> and <b>LCDINIT#</b> .		± 5	μA	0 ≤ V <sub>IN</sub> ≤ V <sub>CC</sub>
I <sub>LI2</sub>	Input Leakage Current for <b>TMS</b> , <b>TRST#</b> , and <b>TDI</b> , <b>ONCE#</b> , <b>RAD[8:0]</b> and <b>LCDINIT#</b> .	-140	-250	μA	V <sub>IN</sub> = 0.45 V (1)
I <sub>LO</sub>	Output Leakage Current		± 5	μA	0.4 ≤ V <sub>OUT</sub> ≤ V <sub>CC</sub>
I <sub>CC</sub> Active (Power Supply)	Power Supply Current		1.45	A	(1,2)
I <sub>CC</sub> Active (Thermal)	Thermal Current	1.1		A	(1,3)
I <sub>CC</sub> Active (Power Modes)	Reset Mode ONCE Mode		0.95 0.02	A	(4) (4)

**NOTES:**

- Measured with device operating and outputs loaded to the test condition in [Figure 13](#).
- I<sub>CC</sub> Active (Power Supply) value is provided for selecting your system's power supply. It is measured using one of the worst case instruction mixes with V<sub>CC</sub> = 3.6 V and ambient temperature = 55°C.
- I<sub>CC</sub> Active (Thermal) value is provided for your system's thermal management. Typical I<sub>CC</sub> is measured with V<sub>CC</sub> = 3.3 V and ambient temperature = 55°C.
- I<sub>CC</sub> Test (Power modes) refers to the I<sub>CC</sub> values that are tested when the device is in Reset mode or ONCE mode with V<sub>CC</sub> = 3.6 V and ambient temperature = 55°C.

## 4.5 Targeted AC Specifications

### 4.5.1 Clock Signal Timings

**Table 23. Input Clock Timings**

Symbol	Parameter	Min	Max	Units	Notes
$T_F$	<b>P_CLK</b> Frequency	16	33.33	MHz	
$T_C$	<b>P_CLK</b> Period	30	62.5	ns	(1)
$T_{CS}$	<b>P_CLK</b> Period Stability		$\pm 250$	$\pi\sigma$	Adjacent Clocks (2)
$T_{CH}$	<b>P_CLK</b> High Time	12		ns	Measured at 1.5 V (2)
$T_{CL}$	<b>P_CLK</b> Low Time	12		ns	Measured at 1.5 V (2)
$T_{CR}$	<b>P_CLK</b> Rise Time	1	4	V/ns	0.4 V to 2.4 V (2)
$T_{CF}$	<b>P_CLK</b> Fall Time	1	4	V/ns	2.4 V to 0.4 V (2)
$T_{DICS}$	<b>DCLKIN</b> Period Stability		$\pm 250$	$\pi\sigma$	Adjacent Clocks (2)
$T_{DICH}$	<b>DCLKIN</b> High Time	5		ns	Measured at 1.5 V (2)
$T_{DICL}$	<b>DCLKIN</b> Low Time	5		ns	Measured at 1.5 V (2)

**NOTES:**

1. See [Figure 8 “P\\_CLK, TCK, DCLKIN, DCLKOUT Waveform”](#) on page 43.
2. Not tested.

**Table 24. SDRAM Output Clock Timings**

Symbol	Parameter	Min	Max	Units	Notes
$T_{DOF}$	<b>DCLKOUT</b> Frequency		$2T_F$	MHz	
$T_{DOC}$	<b>DCLKOUT</b> Period		$T_C / 2$	ns	(1)
$T_{DOCS}$	<b>DCLKOUT</b> Period Stability		$\pm 250$	$\pi\sigma$	Adjacent Clocks
$T_{DOCH}$	<b>DCLKOUT</b> High Time	5		ns	Measured at 1.5 V
$T_{DOCL}$	<b>DCLKOUT</b> Low Time	5		ns	Measured at 1.5 V

**NOTE:**

1. See [Figure 8 “P\\_CLK, TCK, DCLKIN, DCLKOUT Waveform”](#) on page 43.

## 4.5.2 PCI Interface Signal Timings

Table 25. PCI Signal Timings

Symbol	Parameter	Min	Max	Units	Notes
T <sub>OV1</sub>	Output Valid Delay from P_CLK - PCI Signals Except P_REQ#, P_INT[A:D]#, and S_GNT[5:0]#	2	11	ns	(1,2)
T <sub>OV2</sub>	Output Valid Delay from P_CLK - P_INT[A:D]#	0	25	ns	(1,2,6)
T <sub>OV4</sub>	Output Valid Delay from P_CLK - P_REQ# and S_GNT[5:0]#	2	12	ns	(1,2)
T <sub>OF</sub>	Output Float Delay from P_CLK		28	ns	(1,4,5,6)
T <sub>IS1</sub>	Input Setup to P_CLK - PCI Signals Except P_GNT# and S_REQ[5:0]#	7		ns	(1,3)
T <sub>IS2</sub>	Input Setup to P_CLK - P_GNT#	10		ns	(1,3)
T <sub>IS3</sub>	Input Setup to P_CLK - S_REQ[5:0]#	12		ns	(1,3)
T <sub>IH1</sub>	Input Hold from P_CLK - PCI Signals	0		ns	(1,3)
T <sub>IS4</sub>	Input Setup to P_CLK - S_INT[A:D]#	25		ns	(1,3,7,8)
T <sub>IH2</sub>	Input Hold to P_CLK - S_INT[A:D]#	2		ns	(1,3,7,8)
T <sub>IS5</sub>	Input Setup to P_CLK - P_RST#	6		ns	(1,3,7)
T <sub>IH3</sub>	Input Hold to P_CLK - P_RST#	2		ns	(1,3,7)

**NOTES:**

1. The *PCI Local Bus Specification*, Revision 2.1 requires that all of the PCI signal AC timings use 0 pF for minimum timings and 50 pF for maximum timings.
2. See [Figure 9 “T<sub>OV</sub> Output Delay Waveform” on page 43](#).
3. See [Figure 11 “T<sub>IS</sub> and T<sub>IH</sub> Input Setup and Hold Waveform” on page 44](#).
4. A float condition occurs when the output current becomes less than I<sub>LO</sub>. Float delay is not tested. See [Figure 10 “T<sub>OF</sub> Output Float Waveform” on page 44](#).
5. See [Figure 10 “T<sub>OF</sub> Output Float Waveform” on page 44](#).
6. Outputs precharged to V<sub>CC5</sub>.
7. P\_RST#, S\_INT[A:D]# may be synchronous or asynchronous. Meeting setup and hold time guarantees recognition at a particular clock edge.
8. S\_INT[A:D]# must be asserted for a minimum of two P\_CLK periods to guarantee recognition.

### 4.5.3 JN Core Interface Timings

Table 26. JN Core Signal Timings

Symbol	Parameter	Min	Max	Units	Notes
$T_{OV5}$	Output Valid Delay from <b>P_CLK - FAIL#</b>	2	TBD	ns	(1,5)
$T_{IS7}$	Input Setup to <b>P_CLK - NMI#, XINT[5:4]#</b>	25		ns	(2,3)
$T_{IH5}$	Input Hold from <b>P_CLK - NMI#, XINT[5:4]#</b>	2		ns	(2,3)

**NOTES:**

1. See Figure 9 “ $T_{OV}$  Output Delay Waveform” on page 43.
2. See Figure 11 “ $T_{IS}$  and  $T_{IH}$  Input Setup and Hold Waveform” on page 44.
3. Setup and hold times must be met for proper processor operation. **NMI#** and **XINT[5:4]#** may be synchronous or asynchronous. Meeting setup and hold time guarantees recognition at a particular clock edge. For asynchronous operation, **NMI#** and **XINT[5:4]#** must be asserted for a minimum of two **P\_CLK** periods to guarantee recognition.
4. Core signals include: **XINT[5:4]#**, **NMI#**, **FAIL#**.
5. The processor asserts **FAIL#** during built-in self-test. If self-test passes, **FAIL#** is deasserted. The processor asserts **FAIL#** during the bus confidence test. If the test passes, **FAIL#** is deasserted and user program execution begins.

### 4.5.4 SDRAM/Flash Interface Signal Timings

Table 27. SDRAM / Flash Signal Timings

Symbol	Parameter	Min	Max	Units	Notes
$T_{OV6}$	Output Valid Delay from <b>DCLKIN - SA[11:0], SBA[1:0], SCAS#, SRAS#, and SWE#</b> .	1.62	6.6	ns	(1,5)
$T_{OV7}$	Output Valid Delay from <b>DCLKIN - DQ[63:0], and SCB[7:0]</b> .	2.03	7.14	ns	(1,5)
$T_{OV8}$	Output Valid Delay from <b>DCLKIN - SDQM[7:0]</b>	2.57	6.85	ns	(1,5)
$T_{OV9}$	Output Valid Delay from <b>DCLKIN - SCKE[1:0]</b>	1.74	5.5	ns	(1,5)
$T_{OV10}$	Output Valid Delay from <b>DCLKIN - SCE[1:0]#</b>	1.65	5.25	ns	(1,5)
$T_{IS8}$	Input Setup to <b>DCLKIN - DQ[63:0], and SCB[7:0]</b>	3		ns	(2)
$T_{IH6}$	Input Hold from <b>DCLKIN - DQ[63:0], and SCB[7:0]</b>	1.5		ns	(2)
$T_{OV11}$	Output Valid Delay from <b>DCLKIN - RAD[16:0], RALE, RCE[1:0]#, ROE#, and RWE#</b> .	1.4	11	ns	(1,5)
$T_{IS9}$	Input Setup to <b>DCLKIN - RAD[16:0]</b>	5		ns	(2)
$T_{IH7}$	Input Hold from <b>DCLKIN - RAD[16:0]</b>	1.4		ns	(2)

**NOTES:**

1. See Figure 9 “ $T_{OV}$  Output Delay Waveform” on page 43.
2. See Figure 11 “ $T_{IS}$  and  $T_{IH}$  Input Setup and Hold Waveform” on page 44.
3. SDRAM signals include **SA[11:0]**, **SBA[1:0]**, **SCAS#**, **SCE[1:0]#**, **SCKE[1:0]**, **SDQM[7:0]**, **SRAS#**, **SWE#**, **DQ[63:0]**, and **SCB[7:0]**. Timings are for 3.3V signalling environment.
4. Flash signals include **RAD[16:0]**, **RALE**, **RCE[1:0]#**, **ROE#**, and **RWE#**. Timings are for 5 V signalling environment.
5. These output valid times are specified with a 0 pF loading.

## 4.5.5 Boundary Scan Test Signal Timings

Table 28. Boundary Scan Test Signal Timings

Symbol	Parameter	Min	Max	Units	Notes
$T_{BSF}$	TCK Frequency	0	$0.5T_F$	MHz	
$T_{BSCH}$	TCK High Time	15		ns	Measured at 1.5 V (1)
$T_{BSCL}$	TCK Low Time	15		ns	Measured at 1.5 V (1)
$T_{BSCR}$	TCK Rise Time		5	ns	0.8 V to 2.0 V (1)
$T_{BSCF}$	TCK Fall Time		5	ns	2.0 V to 0.8 V (1)
$T_{BSIS1}$	Input Setup to TCK — TDI, TMS	4		ns	(4)
$T_{BSIH1}$	Input Hold from TCK — TDI, TMS	6		ns	(4)
$T_{BSIS2}$	Input Setup to TCK — TRST#	25		ns	(4)
$T_{BSIH2}$	Input Hold from TCK — TRST#	3		ns	(4)
$T_{BSOV1}$	TDO Valid Delay	3	30	ns	Relative to falling edge of TCK (2, 3)
$T_{OF1}$	TDO Float Delay	3	30	ns	Relative to falling edge of TCK (2, 5)
$T_{OV12}$	All Outputs (Non-Test) Valid Delay	3	30	ns	Relative to falling edge of TCK (2, 3)
$T_{OF2}$	All Outputs (Non-Test) Float Delay	3	30	ns	Relative to falling edge of TCK (2, 5)
$T_{IS10}$	Input Setup to TCK — All Inputs (Non-Test)	4		ns	(4)
$T_{IH8}$	Input Hold from TCK — All Inputs (Non-Test)	6		ns	(4)

**NOTES:**

1. Not tested.
2. Outputs precharged to  $V_{CC5}$ .
3. See [Figure 9 "T<sub>OV</sub> Output Delay Waveform"](#) on page 43.
4. See [Figure 11 "T<sub>IS</sub> and T<sub>IH</sub> Input Setup and Hold Waveform"](#) on page 44.
5. A float condition occurs when the output current becomes less than  $I_{LO}$ . Float delay is not tested. See [Figure 10 "T<sub>OF</sub> Output Float Waveform"](#) on page 44.

## 4.5.6 I<sup>2</sup>C Interface Signal Timings

Table 29. I<sup>2</sup>C Interface Signal Timings

Symbol	Parameter	Std. Mode		Fast Mode		Units	Notes
		Min	Max	Min	Max		
F <sub>SCL</sub>	SCL Clock Frequency	0	100	0	400	KHz	
T <sub>BUF</sub>	Bus Free Time Between STOP and START Condition	4.7		1.3		μs	(1)
T <sub>HDSTA</sub>	Hold Time (repeated) START Condition	4		0.6		μs	(1,3)
T <sub>LOW</sub>	SCL Clock Low Time	4.7		1.3		μs	(1,2)
T <sub>HIGH</sub>	SCL Clock High Time	4		0.6		μs	(1,2)
T <sub>SUSTA</sub>	Setup Time for a Repeated START Condition	4.7		0.6		μs	(1)
T <sub>HDDAT</sub>	Data Hold Time	0		0	0.9	μs	(1)
T <sub>SUDAT</sub>	Data Setup Time	250		100		ns	(1)
T <sub>SR</sub>	SCL and SDA Rise Time		1000	20+0.1C <sub>b</sub>	300	ns	(1,4)
T <sub>SF</sub>	SCL and SDA Fall Time		300	20+0.1C <sub>b</sub>	300	ns	(1,4)
T <sub>SUSTO</sub>	Setup Time for STOP Condition	4		0.6		μs	(1)

**NOTES:**

1. See [Figure 12](#).
2. Not tested.
3. After this period, the first clock pulse is generated.
4. C<sub>b</sub> = the total capacitance of one bus line, in pF.

## 4.6 AC Timing Waveforms

Figure 8. P\_CLK, TCK, DCLKIN, DCLKOUT Waveform

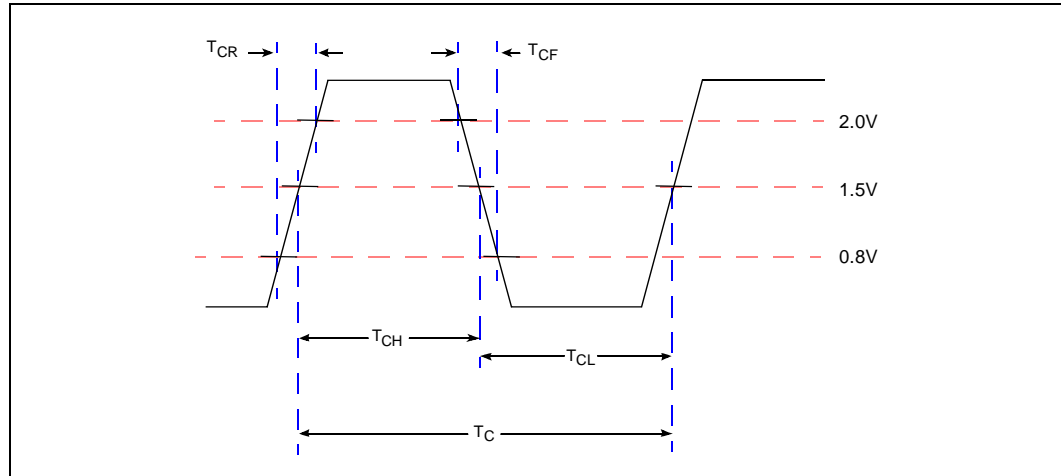

Figure 9.  $T_{OV}$  Output Delay Waveform

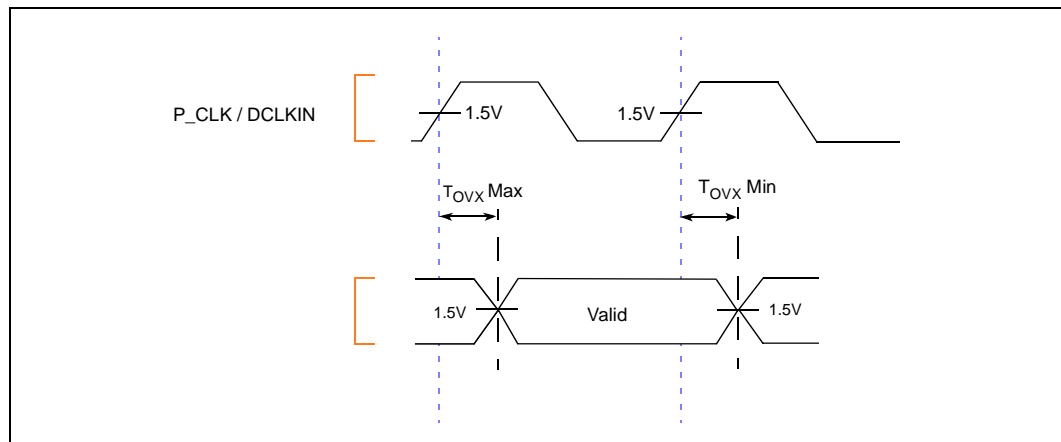



Figure 10.  $T_{OF}$  Output Float Waveform

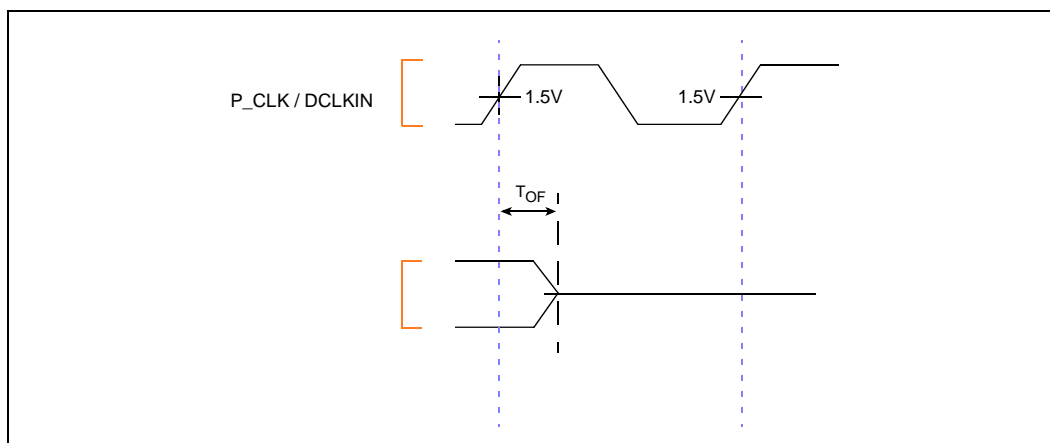

Figure 11.  $T_{IS}$  and  $T_{IH}$  Input Setup and Hold Waveform

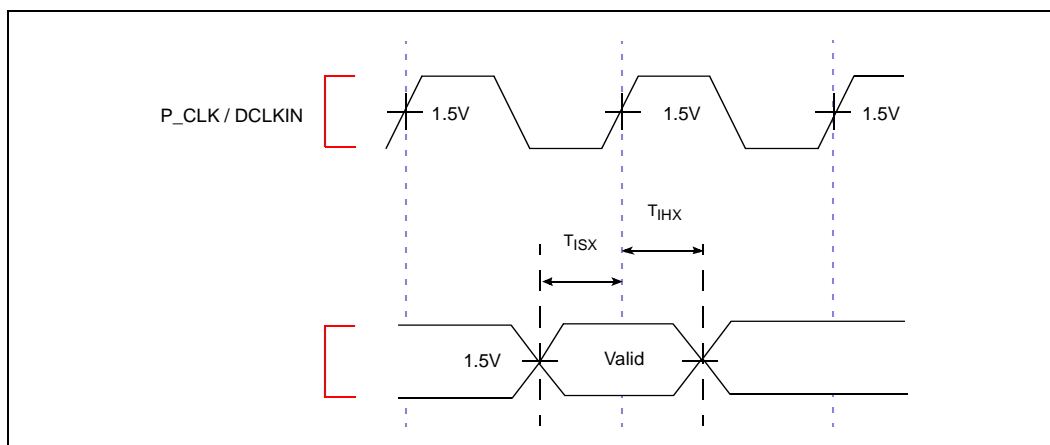
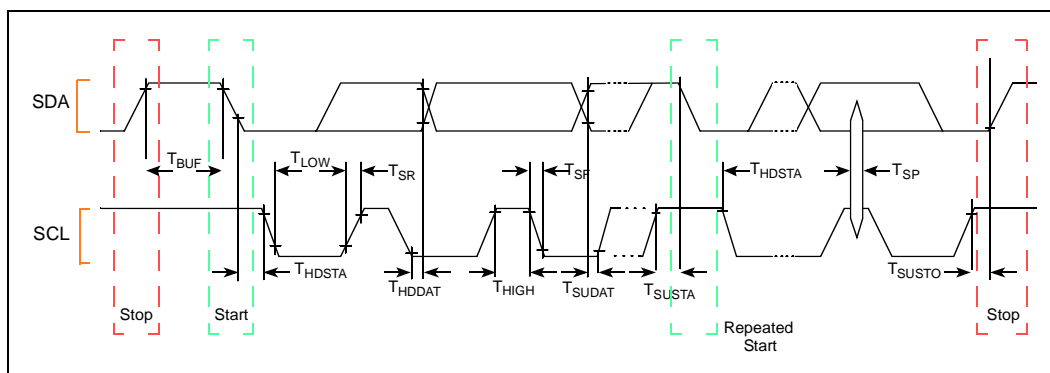

Figure 12. I<sup>2</sup>C Interface Signal Timings



## 4.7 AC Test Conditions

The AC specifications in [Section 4.5, “Targeted AC Specifications”](#) on page 38 are tested with a 50 pF load indicated in [Figure 13](#).

**Figure 13. AC Test Load (all signals except SDRAM and Flash signals)**

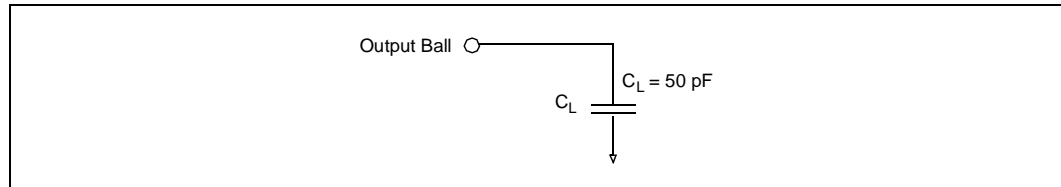

The PCI maximum AC specifications are tested with the 50 pF load indicated in [Figure 13](#). The PCI minimum AC specifications are tested with a 0 pF load. All of the SDRAM and Flash timings are specified for a 0 pF load.

## 5.0 Device Identification on Reset

During the manufacturing process, values characterizing the i960 RM/RN I/O processor type and stepping are programmed into memory-mapped registers. The i960 RM/RN I/O processor contains two read-only device ID MMRs. One holds the Processor Device ID (PDIDR MMR Location - 0000 1710H) and the other holds the i960 Core Processor Device ID (DEVICEID MMR Location - FF00 8710H). During initialization, the PDIDR is placed in g0.

The device identification values are compliant with the IEEE 1149.1 specification and Intel standards. Table 30 describes the fields of the two Device IDs.

**Note:** The value programmed into these registers varies with stepping. Refer to the Specification Update for the correct value.

**Table 30. Device ID Registers**

Bit	Default	Description
31:28	X	Version - Indicates stepping changes.
27	X	V <sub>CC</sub> - Indicates device voltage type. 0 = 5.0 V 1 = 3.3 V
26:21	X	Product Type - Indicates the generation or "family member".
20:17	X	Generation Type - Indicates the generation of the device.
16:12	X	Model Type - Indicates member within a series and specific model information.
11:01	X	Manufacturer ID - Indicates manufacturer ID assigned by IEEE. 0000 0001 001 = Intel Corporation
0	1	Constant